



CE



**VdS** G 517002  
Anerkennungs-Nr.  
approval-no.

**VdS** 0786 - CPD - 50680  
EN 12101-10:2005 + Corr. 1:2007  
conform

## Content

Important regulations.....	2
Introduction.....	2
Safety information.....	2
Pictogram explanation.....	2
Intended use.....	3
SHEV opening.....	3
Example of application.....	3
Performance features.....	3
Overview of components.....	4
Control module – CM-BT1-D4-P2.....	5
Supply module – PSM-1-24-040.....	5
Trigger module – TMD-1-ACR.....	5
Control module – CM-B-1-D4-P2.....	5
Trigger module – TMA-1-D4-D12.....	5
Actuator module – AM-1-2-10-24-D6-D2.....	5
Actuator module – AM-B-1-2-10-24-D4-D2.....	6
Bistable relay module – BRM-1-COC-0006.....	6
AD I/O module – ADM-AD1-1212-4.....	6
Actuator module – AM-1-1-08-230-D4-D2.....	6
Digital I/O module – IOM-D1-1212.....	6
ACB interface.....	6
Power packs PS-S1-24-20 and PS-S1-24-40.....	7
Technical data.....	8
24 V emergency supply.....	8
Declaration of conformity.....	8
Arrangement of the modules.....	9
Installation of the module sockets.....	9
Removal of the module sockets.....	9
General instructions for connection.....	10
Wiring diagram (sample).....	10
Connection – PSM.....	11
Connection – CM / CM-B.....	12
Connection – Digital inputs and outputs.....	13
Further top hat rail levels for additional CPS-M modules (Not for CM-B). 13	
Battery for the clock of the event memory.....	13
Connection – IOM.....	14
Connection – BRM.....	15
Connection – ADM.....	16
Connection – ADM.....	17
Connection – AM 24 / AM-B 24.....	18
Connection – Vent buttons to AM 24 / AM-B 24.....	18
Connection – AM 24 with ACB drives.....	19
Connection – AM 24 / AM-B 24 with pole-changing drives.....	19
Connection – AM 230.....	20
Connection – NSV 401 control and vent button to AM 230.....	20
Connection – NSV 401 power supply and D+H ACB drives.....	21
Connection – NSV 401 power supply and D+H drives.....	21
Connection – NSV 401 power supply and third-party drives.....	22
Connection – TMA.....	23
Connection – TMA (2 lines).....	24
Connection – TMA parallel connection RT.....	25
Connection – TMA to fire alarm system (FAS).....	25
Connection – TMD-1-ACR.....	26
Connection – Ringbus RT 46-ACR (-SD-ACB).....	26
Connection – Ringbus TMD-1-ACR.....	26
Connection – Periphery RT 46-ACR-SD-ACB.....	27
Connection – Digital inputs and outputs.....	27
Connection – RM line (analogue monitoring).....	27
Connection – External ventilation buttons.....	27
Connection – Addressable RM line (digital monitoring).....	27
Description of the inputs and outputs.....	28
230 V AC Emergency power supply – NSV 401.....	29
Schematic design – NSV 401.....	30
Connection overview – NSV 401.....	31
Connecting / changing batteries.....	32
Commissioning and configuration with the SCS software.....	33
Description of the software functions.....	34
Operation – Touch panel (optional).....	35
Operation – Daily ventilation.....	36
Operation – Weather automation.....	36
Operation – SHEV.....	36
Operation – Trigger on alarm.....	37
Operation – Closing after alarm.....	37
Inspection.....	40
Maintenance and cleaning.....	40
Disposal.....	40

## Important regulations

It is necessary to observe VDE 0833 for danger alarm systems, VdS 2221, VDE 0100 for electrical systems, DIN 18232 for SHEV systems, the provisions of the local fire brigade and of the energy supply company for the mains connection.

## WARNING

Read all the safety information, instructions, images and technical data provided with this product.  
Failure to observe the following instructions can result in electric shock, fire and/or serious injury.  
Keep all the safety information and instructions in a safe place for future reference.

## Introduction

Your D+H service and sales partner  
Safety in the building is not only provided by the product. Safety is created above all by competence. All D+H service and sales partners are certified and regularly trained SHEV specialist companies. They work closely with D+H Mechatronic AG as the manufacturer to implement comprehensive system solutions for SHEV and natural building ventilation. With holistic support and continuous quality assurance in every phase of the project: from consulting, planning and project configuration to installation, commissioning, maintenance and service. This means that the highest national and international quality standards are reliably fulfilled.

**Installation and commissioning**  
The comprehensive network of D+H service and sales partners is available to you for proper installation and commissioning. Our partner system guarantees that D+H products are installed exclusively by trained and experienced technicians in compliance with the technical directives and regulations. Personal transfer and instruction of the operators are included.

**Maintenance and repairs**  
Building operators are responsible for the functional reliability of safety devices in their own buildings.  
Regular and proper maintenance ensures thbhgd

at your system will always be operational. As SHEV specialist companies, the D+H service and sales partners are optimally qualified for the maintenance. Owners/operators can demonstrate at any time that they have fulfilled their obligation by means of a service contract.



**Quality with a warranty**  
You receive extended warranty benefits for all D+H SHEV systems that were installed by a D+H service and sales partner and are regularly maintained. Ask your local D+H service and sales partner about this.

**Always in your neighbourhood**  
We are represented around the globe with our network of subsidiaries and exclusive partners.  
Looking for a local D+H partner?  
Simply visit our website:  
[www.dh-partner.com](http://www.dh-partner.com)

## Safety information

230 V AC operating voltage!  
Risk of injury from electric shock!  
• Only an authorised, electrically skilled person is allowed to connect the power  
• Keep children away from the controller  
• Only use in dry spaces  
• Only intended for installation indoors  
• Only use unaltered D+H original parts

## Pictogram explanation

	Control panel O.K.
	Fault
	SHEV alarm

## Intended use

- Modular SHEV controller for complex control tasks
- Can be used in the AdComNet SHEV bus system
- Combine lines and groups however you want
- Convenience functions for daily ventilation
- Only intended for installation indoors

## SHEV opening

In case of fire, the SHEV opening should enable flue gases to flow out with as little hindrance as possible.

The size, type and positioning of the SHEV opening is of critical importance for the optimum effect. These specifications are defined in the relevant regulations of the respective country. More information about this is also available at [www.rwa-heute.de](http://www.rwa-heute.de).

The SHEV opening should be coordinated with the responsible fire prevention authority.

## Performance features

- Flexible design for implementing decentralized, central and combined SHEV systems
- AdComNet bus system for seamless networking of the modules within the CPS-M and further D+H AdComNet SHEV control system
- Simple implementation of complex SHEV scenarios
- High flexibility and expandability
- Each control panel functions autonomously when the bus connection fails
- Programming via the D+H Service and Configuration Suite (SCS)
- No specialised system integrator required
- Can be carried out by any trained D+H partner
- The control panel can receive firmware updates via the USB interface on the CM module
- Approved by VdS in accordance with EN 12101-10
- Electrical interconnection of the modules using plug connectors integrated into the bases
- Freely selectable group assignment, can be changed at any time
- All 24 V outputs are short-circuit resistant and electronically protected by a fuse
- Assemblies can be retrofitted during building modification
- Lockable surface-mounted sheet steel housing
- Installation of all modules on a 35 mm top hat rail

## Example of application

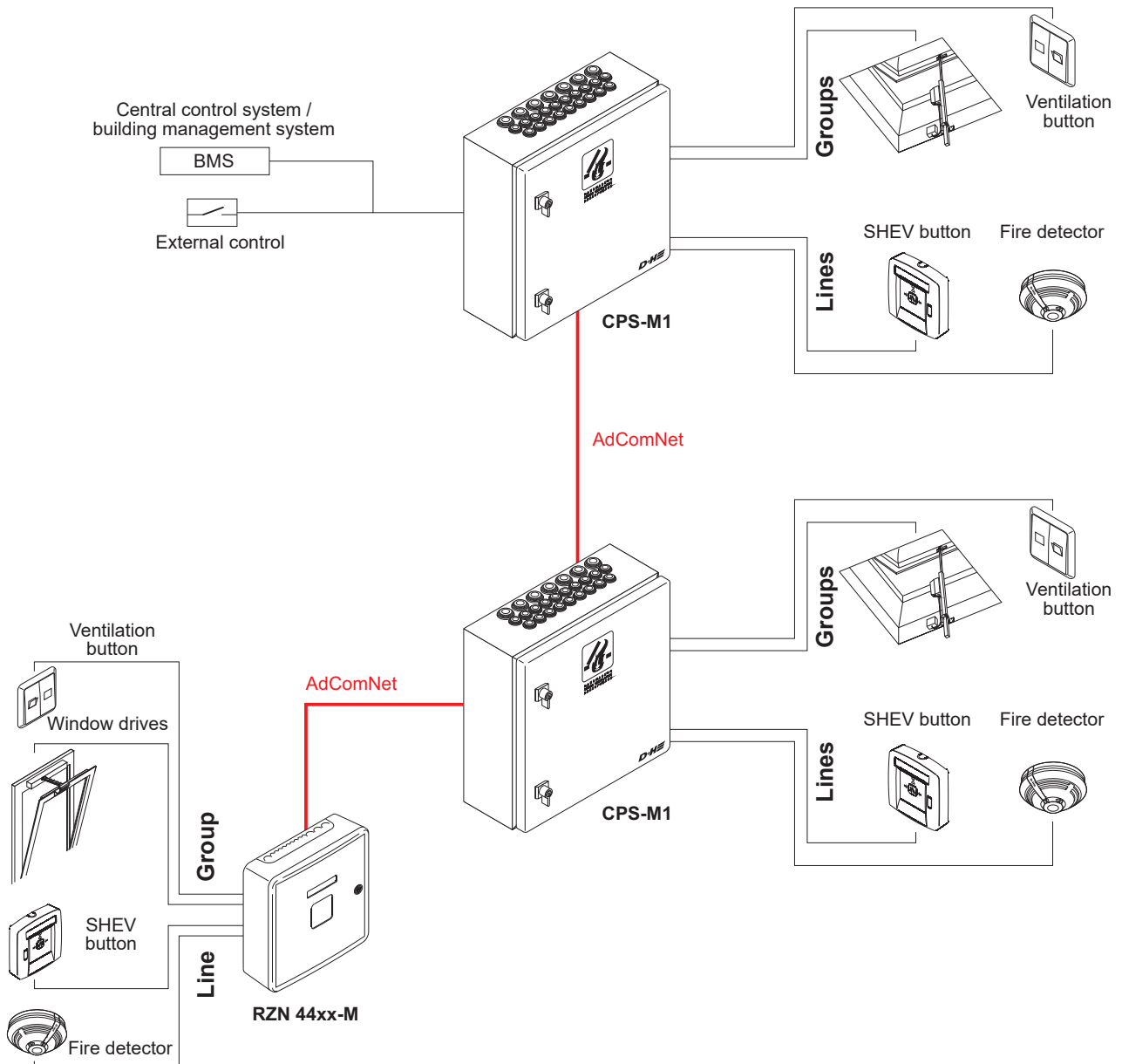

# Overview of components

Basic module socket  
MS-D1-RR-TS

Supply module socket  
MS-S1-RD-TS

Expansion module socket  
MS-S1-DD-TS

Bus termination module  
BTM-1-1  
Is plugged into the last  
module socket.



Bus connection  
Connection for the  
power supply

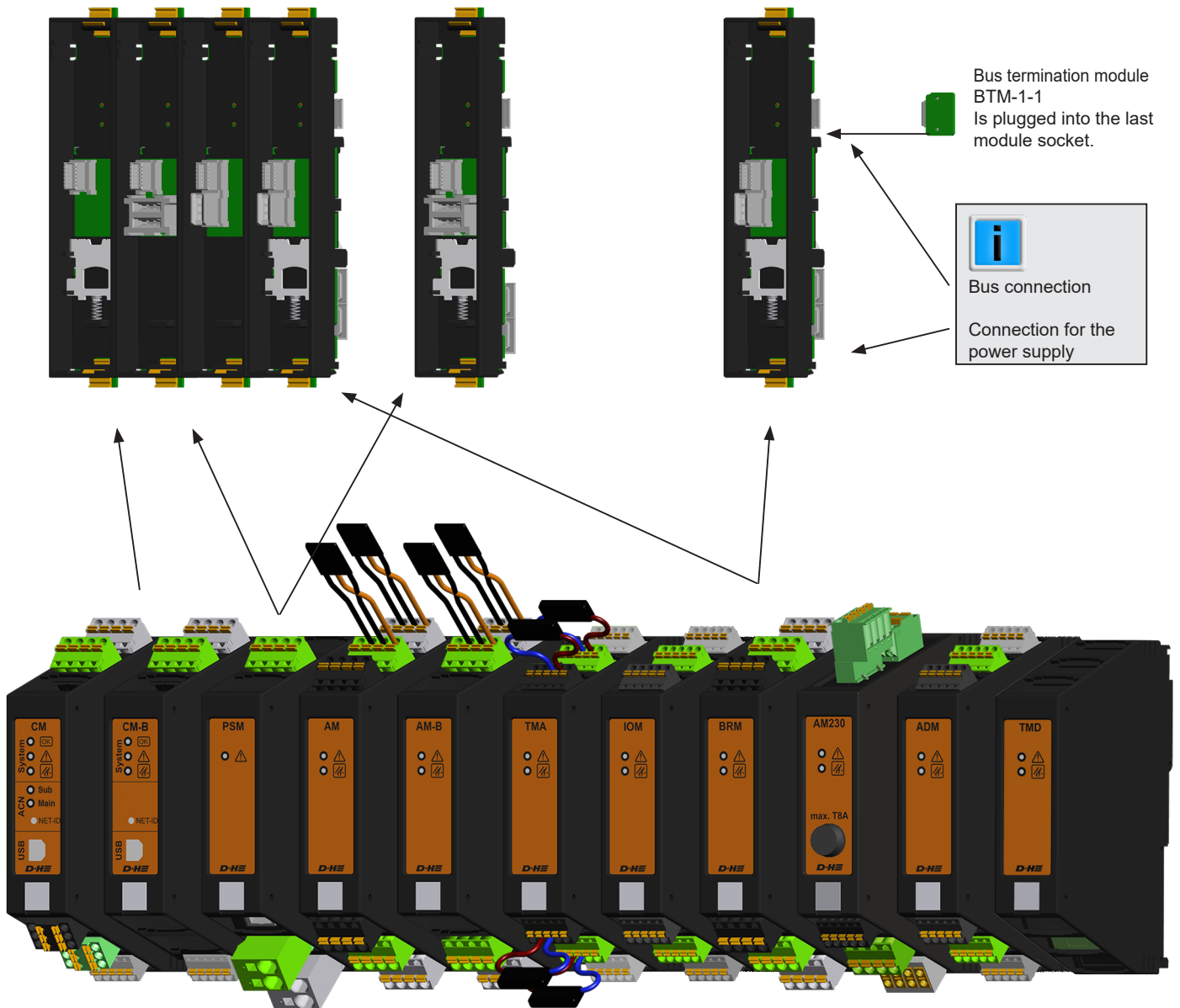

- Control module  
CM-BT1-D4-P2
- Control module  
CM-B-1-D4-P2
- Mains supply module  
PSM-1-24-040
- 24 V DC actuator module  
AM-1-2-10-24-D6-D2
- 24 V DC actuator module  
AM-B-1-2-10-24-D4-D2
- Analogue trigger module  
TMA-1-D4-D12
- Digital I/O module  
IOM-D1-1212
- Bistable relay module  
BRM-1-COC-0006
- 230 V AC actuator module  
AM-1-1-08-230-D4-D2
- Analogue / Digital  
I/O module ADM-AD1-1212-4
- Digital trigger module  
TMD-1-ACR

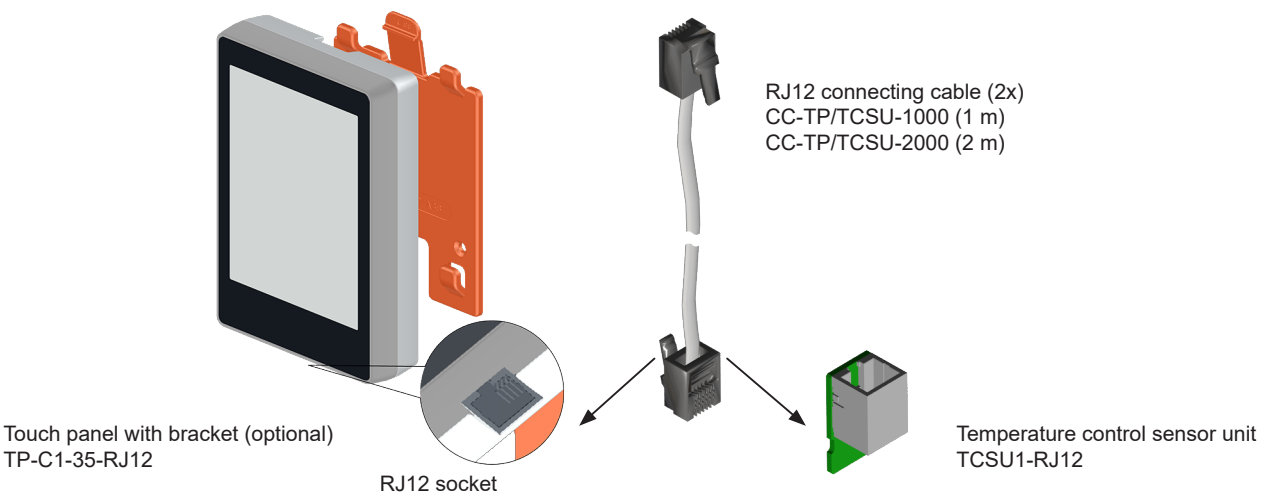

## Control module – CM-BT1-D4-P2

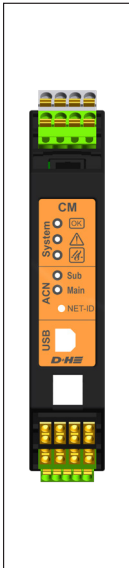

- Central control element of the control panel (segment coupler)
- One CM controller module is required for each CPS-M
- Each CM controller module can manage up to 29 additional modules (PSM, AM, TMA)
- AdComNet interfaces for implementing decentralised systems in combination with other AdComNet control panels
- 1000 SCS links and 100 connectors possible
- USB interface for configuring the system and the connected drives (only ACB), and for firmware updates of the control panel
- Integrated LEDs to indicate operation (green), fault (yellow), alarm (red) and AdComNet operation
- Status displays for all modules of the respective CPS-M as well as emergency operation of the individual lines and groups using the 3.5" TFT touch panel
- Three user-programmable digital inputs for connecting buttons, switches, external controls etc.
- Two user-programmable, isolated change-over contacts, for example, for fault and alarm notifications
- Integrated event memory for system analysis and traceability
- Connection using removable spring-type terminals
- Conductor cross-sections max. 1.5 mm<sup>2</sup> flexible
- Dimensions WxHxD: 26x130x125 mm
- Installation on a 35 mm top hat rail in combination with a basic module socket

## Control module – CM-B-1-D4-P2

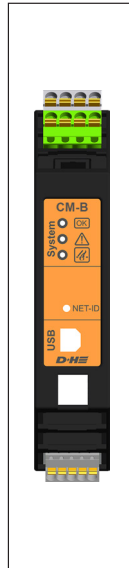

- Central control element of the control panel (segment coupler)
- One CM controller module is required for each CPS-M
- Each CM controller module can manage up to 29 additional modules (PSM, AM, TMA)
- 30 SCS links and 10 connectors possible
- USB interface for configuring the system and the connected drives (only ACB), and for firmware updates of the control panel
- Integrated LEDs to indicate operation (green), fault (yellow), alarm (red) and AdComNet operation
- Status displays for all modules of the respective CPS-M as well as emergency operation of the individual lines and groups using the 3.5" TFT touch panel
- Three user-programmable digital inputs for connecting buttons, switches, external controls etc.
- Two user-programmable, isolated change-over contacts, for example, for fault and alarm notifications
- Integrated event memory for system analysis and traceability
- Connection using removable spring-type terminals
- Conductor cross-sections max. 1.5 mm<sup>2</sup> flexible
- Dimensions WxHxD: 26x130x125 mm
- Installation on a 35 mm top hat rail in combination with a basic module socket

## Supply module – PSM-1-24-040



- Power supply of the control panel system
- Max. 40 A load current for each supply module depending on the power supply unit
- If a load current of more than 40 A is required, another PSM (including supply module socket) can be used.
- The PSM always provides power to the actuator and trigger modules used to the right of it
- Automatic toggling between mains supply and battery supply in case of a mains outage
- Max. battery capacity 26 Ah (battery type 6)
- 72 hours of emergency supply time
- Integrated protection against excessive discharge
- Temperature-controlled charging voltage with external temperature sensor
- Integrated LED to indicate a fault (yellow)
- Two connections for peripherals that are and are not supplied with emergency power
- Connection using removable spring-type terminals
- Conductor cross-sections max. 2.5 mm<sup>2</sup> flexible or for supply and battery 6 mm<sup>2</sup> flexible
- Dimensions WxHxD: 26x130x125 mm
- Installation on a 35 mm top hat rail in combination with a basic module socket or for more than one power supply unit with a supply module socket

## Trigger module – TMA-1-D4-D12

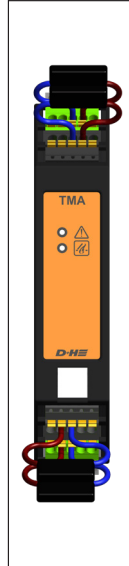

- Module for connecting trigger peripheral devices
- Two independent lines for connecting a max. of 10 SHEV buttons and 30 fire detectors per line (only detectors approved by D+H may be used)
- Cables are monitored by the EM-L01 terminal module
- The SCS software can be used to configure the lines also as user-programmable digital inputs and outputs
- Integrated LEDs to indicate a fault (yellow) and alarm (red)
- Connection using removable spring-type terminals
- Conductor cross-sections max. 1.5 mm<sup>2</sup> flexible
- Dimensions WxHxD: 26x130x125 mm
- Installation on a 35 mm top hat rail in combination with an expansion module socket

## Trigger module – TMD-1-ACR

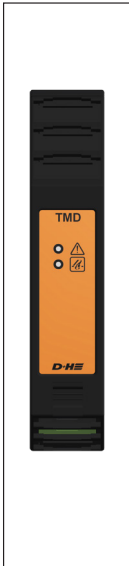

- The module is intended exclusively for use in the modular SHEV controller CPS-M1.
- Per TMD max. 250 detectors
- Configuration using SCS is required for commissioning the module and the connected devices.
- Safe operation of the subscribers guaranteed even in the event of individual wiring errors.
- Integrated LEDs to indicate a fault (yellow) and alarm (red)
- Connection using removable spring-type terminals
- Conductor cross-sections max. 1.5 mm<sup>2</sup> flexible
- Dimensions WxHxD: 26x130x125 mm
- Installation on a 35 mm top hat rail in combination with an expansion module socket

**Compatible with:** RT BE46-ACR  
RT BE46-ACR-SD-ACB  
RT 46-ACR  
RT 46-ACR-SD-ACB

## Actuator module – AM-1-2-10-24-D6-D2

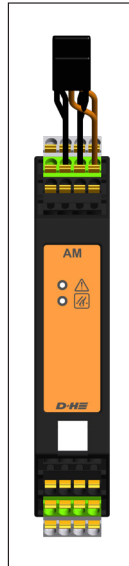

- Module for connecting 24 V DC actuators
- 2 independent groups for connecting drives, each with a total maximum current of 10 A
- The cable is monitored for breaks and short circuits via the terminal module EM-47K
- Each group is electronically protected against overload
- 4 user-programmable digital inputs (e.g. ventilation button)
- 2 user-programmable digital outputs (e.g. NOT CLOSED signal)
- 2 integrated ACB interfaces for reading out and configuring the connected ACB drives
- Can be used with 24 V DC pole-changing drives, ACB drives, spring-return motors and magnets
- Virtual groups in connection with ACB drives possible
- Adjustable ventilation time and opening width for everyday ventilation
- Integrated LEDs to indicate a fault (yellow) and alarm (red)
- Connection using removable spring-type terminals
- Conductor cross-sections max. 2.5 mm<sup>2</sup> flexible
- Dimensions WxHxD: 26x130x125 mm
- Installation on a 35 mm top hat rail in combination with an expansion module socket

## Actuator module – AM-B-1-2-10-24-D4-D2

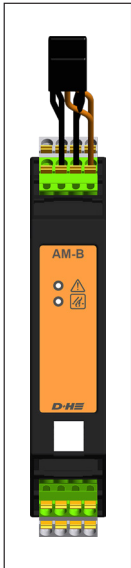

- Module for connecting 24 V DC actuators
- 2 independent groups for connecting drives, each with a total maximum current of 10 A
- The cable is monitored for breaks and short circuits via the terminal module EM-47K
- Each group is electronically protected against overload
- 4 user-programmable digital inputs (e.g. ventilation button)
- 2 user-programmable digital outputs (e.g. NOT CLOSED signal)
- Can be used with 24 V DC pole-changing drives
- Integrated LEDs to indicate a fault (yellow) and alarm (red)
- Connection using removable spring-type terminals
- Conductor cross-sections max. 2.5 mm<sup>2</sup> flexible
- Dimensions WxHxD: 26x130x125 mm
- Installation on a 35 mm top hat rail in combination with an expansion module socket

## Actuator module – AM-1-1-08-230-D4-D2



- Module for connecting 230 V AC actuators
- 1 group for connecting drives with a total maximum current of 8 A
- Up to 45 drives per AM 230 connectable
- D+H 230 V AC drives with SHEV fast mode (HS) are supported
- The cable is monitored for breaks and short circuits via the terminal module EM 230
- 2 user-programmable digital inputs (e.g. ventilation button)
- 1 user-programmable digital output (e.g. NOT CLOSED signal)
- Can be used with 230 V AC standard drives
- Adjustable ventilation time and opening width for everyday ventilation
- Integrated LEDs to indicate a fault (yellow) and alarm (red)
- Connection using removable spring-type terminals
- Conductor cross-sections max. 2.5 mm<sup>2</sup> flexible (230 V AC) or 1.5 mm<sup>2</sup> flexible (24 V DC)
- Dimensions WxHxD: 26x130x125 mm
- Installation on a 35 mm top hat rail in combination with an expansion module socket

## Bistable relay module – BRM-1-COC-0006

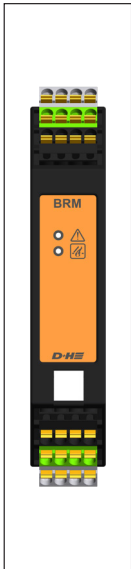

- Six user-programmable, isolated change-over contacts, for switching signals with 24 V DC or 230 V AC
- change-over contacts as bistable version
- Definition of a switch-off state in the event of a mains and battery failure possible (failsafe function)
- Integrated LEDs to indicate a fault (yellow) and alarm (red)
- Connection using removable spring-type terminals
- Conductor cross-sections max. 2.5 mm<sup>2</sup> flexible
- Dimensions WxHxD: 26x130x125 mm
- Installation on a 35 mm top hat rail in combination with an expansion module socket

## Digital I/O module – IOM-D1-1212

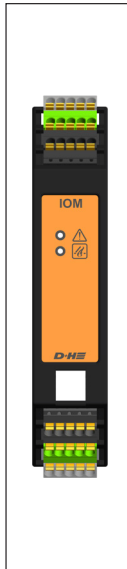

- 12 user-programmable digital inputs
- 12 user-programmable digital outputs
- The digital inputs can also be parameterised as LT inputs
- Integrated LEDs to indicate a fault (yellow) and alarm (red)
- Connection using removable spring-type terminals
- Conductor cross-sections max. 1.5 mm<sup>2</sup> flexible
- Dimensions WxHxD: 26x130x125 mm
- Installation on a 35 mm top hat rail in combination with an expansion module socket

## AD I/O module – ADM-AD1-1212-4

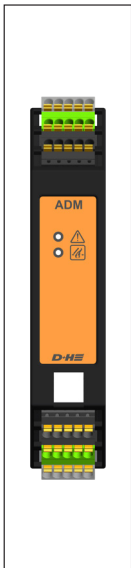

- 4 user-programmable multifunctional inputs (digital or analog)
- 8 user-programmable digital inputs
- 12 user-programmable digital outputs
- 4 virtual adjustable threshold switches per analog input from which a virtual user-configurable digital input is set or reset
- The digital inputs can also be parameterised as LT inputs
- Integrated LEDs to indicate a fault (yellow) and alarm (red)
- Connection using removable spring-type terminals
- Conductor cross-sections max. 1.5 mm<sup>2</sup> flexible
- Dimensions WxHxD: 26x130x125 mm
- Installation on a 35 mm top hat rail in combination with an expansion module socket

## ACB interface

ACB is used for secure communication between the drive and compatible D+H control systems. It enables activation, diagnostics and configuration with perfect position, directly from the control panel. In this process, all status messages, such as the OPEN and CLOSED signals, opening stroke and drive errors are transmitted to the control panel. The ACB bus is based on an open Modbus RTU protocol via which the actuator can be directly controlled and queried. Further information can be found in the D+H ACB Planning Manual.

### Max. Number of drives per ACB connection:

AM 24 = max. 20 ACB drives

AM 230 = max. 20 ACB drives (CDC-5-ACB = max. 15)

In conjunction with locking drives (VLD, FRA), a maximum of 10 drives (incl. locking drives) can be connected.

### Topology of the ACB bus line:

- Stub lines max. 15m
- Total length incl. stubs max. 200m.
- To avoid interference, the cables from the drive to the AM module must be laid close together.

## Power packs PS-S1-24-20 and PS-S1-24-40

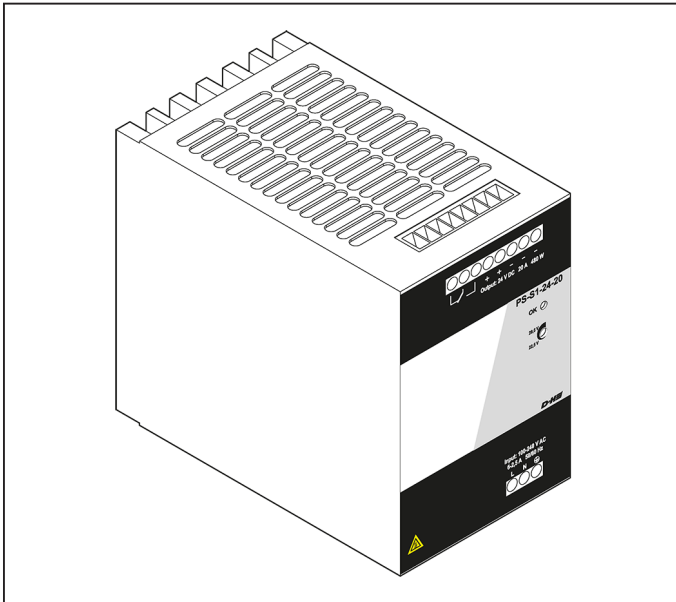

### Functions:

- Output: 24 V DC, 20 A or 40 A
- Installation on 35 mm top hat rail
- Low ripple
- Reverse-voltage protected and short-circuit resistant
- Multiple power supply units can be combined
- For each power supply unit, one PSM supply module is needed

### Technical data:

Type	PS-S1-24-20
Rated input voltage	230 V AC $\pm$ 15%
Frequency	45 to 65 Hz
Nominal power	530 VA / 480 W
Output voltage	24 V DC $\pm$ 1%
Ripple	< 50 mVSS
Output current	20 A
Short-circuit resistant	YES
Can be connected in parallel	YES
Reverse-voltage protected	YES
Input line connection	max. 6 mm <sup>2</sup> star / max. 4 mm <sup>2</sup> flexible
Output line connection	max. 6 mm <sup>2</sup> star / max. 4 mm <sup>2</sup> flexible
Dimensions WxHxD	90x130x150 mm

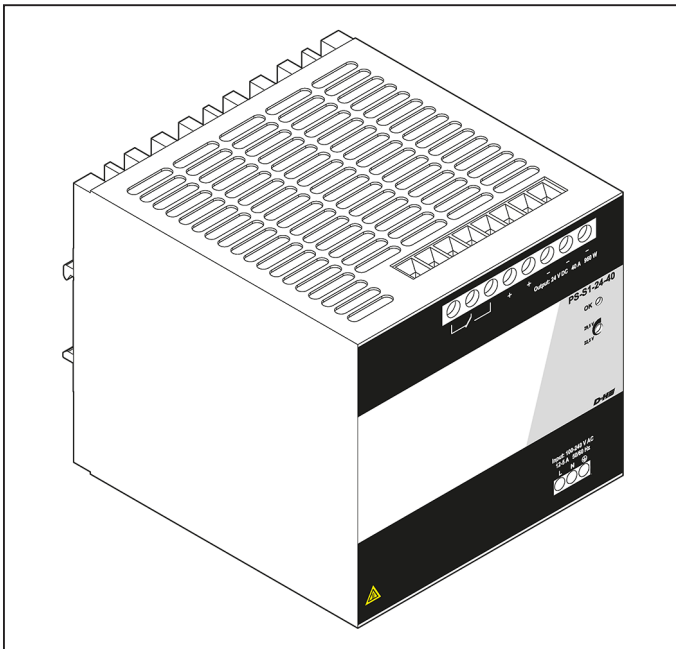

Type	PS-S1-24-40
Rated input voltage	230 V AC $\pm$ 15%
Frequency	45 to 65 Hz
Nominal power	1040 VA / 960 W
Output voltage	24 V DC $\pm$ 1%
Ripple	< 50 mVSS
Output current	40 A
Short-circuit resistant	YES
Can be connected in parallel	YES
Reverse-voltage protected	YES
Input line connection	max. 6 mm <sup>2</sup> star / max. 4 mm <sup>2</sup> flexible
Output line connection	max. 16 mm <sup>2</sup> star / max. 16 mm <sup>2</sup> flexible
Dimensions WxHxD	140x130x150 mm

Conne- ction	Description
L	Phase
N	Neutral
PE	Protective earth
+	24 V DC output
-	

## Technical data

Type	CPS-M1-020-xxxx	CPS-M1-040-xxxx	CPS-M1-060-xxxx	CPS-M1-080-xxxx
Supply*	230 V AC, $\pm 15\%$ , 45 to 60 Hz			
Performance**	530 VA / 480 W ca. 7.5 W	1040 VA / 960 W ca. 8.5 W	1570 VA / 1440 W ca. 16 W	2080 VA / 1920 W ca. 17 W
Performance in standby**				
Output voltage	24 V DC $\pm 1\%$			
Ripple	$< 50 \text{ mV}_{\text{SS}}$			
Nominal output current	20 A	40 A	60 A	80 A
Mode of operation (Einschaltdauer ED / Duty Cycle DC)				
- Monitoring	S1 (Continuous duty, 100 %)			
- Alarm state / ventilation	S6 (Short-time duty, 30 %, 3 min)			
Housing	Sheet steel			
Colour	RAL 7035, light grey			
Type of protection	IP 54 (VdS IP 30)			
Protection class	I			
Temperature range	-5 to +40 °C			
Air humidity	5% to 95% RH			
* For attachments > 120 A or when using an EPS 401, a 400 V connection is required.				
** For 230 V AC systems plus the power of the NSV 401 and the connected 230 V AC drives				

## 24 V emergency supply

- Emergency supply time: 72 hours
- Only use VdS-approved batteries.
- The sum of the nominal currents of the drives and actuators that are triggered when there is an alarm must not exceed the max. permitted load of the respective battery type
- The required battery capacity has to be determined for each PSM.
- The sum of the required ampere-hours (Ah) of all components, including a 30% reserve, must be smaller than the capacity of the battery

Standard batteries:

For each PS-S1-24-20 (+PSM): 2 x battery type 5 (12 V, 18 Ah  $\pm 15\%$ )

For each PS-S1-24-40 (+PSM): 2 x battery type 6 (12 V, 26 Ah  $\pm 15\%$ )

**A special battery calculator is available for the exact determination of the required battery capacity.**

Battery type	Max. permitted load through drives / actuators	Connector
Battery type 4 (12 Ah $\pm 15\%$ )	24 A	Flat plug 6,35 mm
Battery type 5 (18 Ah $\pm 15\%$ )	36 A	hole cable
Battery type 6 (26 Ah $\pm 15\%$ )	52 A	lug $\varnothing 5 \text{ mm}$

Components	Approx. Ah required for 72 hours
Intrinsic consumption by CM / CM-B	0.52 Ah
CM / CM-B supply of the modules	0.018 Ah per module
PSM	0.29 Ah
IOM	0,26 Ah
BRM	0,21 Ah
TMA	0.58 Ah
AM / AM-B	0.43 Ah
AM 230	0,3 Ah
Fire detector	0.005 Ah
Smoke vent button	0.014 Ah
24 V DC Drives / actuators for 180 sec.	0.18 Ah (for each 1 A nominal current)
Alarm devices 250 mA for 180 sec.	0.045 Ah
Devices and digital outputs with an emergency supply (can be adjusted using SCS)	7.2 Ah (for each 100 mA output current)
Digital outputs with an emergency supply (can be adjusted using SCS)	3.6 Ah (for each 50 mA output current)
Touch panel	0.4 Ah
Required capacity = Sum of the required Ah plus a 30% reserve	

## Declaration of conformity

We declare under our sole responsibility that the product described under "Technical Data" complies with the following directives:

2014/30/EU, 2014/35/EU, 2011/65/EU

S.I. 2016/1091, S.I. 2016/1011, S.I. 2012/3032

Technical documents stored at:

D+H Mechatronic AG, D-22949 Ammersbek

Dirk Dingfelder      Maik Schmees

CEO                      CTO

20.08.2025

## Arrangement of the modules

- Each CM controller module can manage up to 29 additional modules (PSM, AM, TMA)
- The first PSM provides power to the CM module as well as to the AM and TMA modules to the right of it
- Each additional PSM always provides power only to the modules to the right of it
- This applies also to the emergency battery power. Therefore, the modules are to be distributed evenly across the PSM modules
- Due to the higher current consumption and shorter cable paths, the AM 24 modules are each to be used first next to the PSM module
- The total current of the drives respectively connected to the PSM must not exceed the output current of the respective power supply unit.

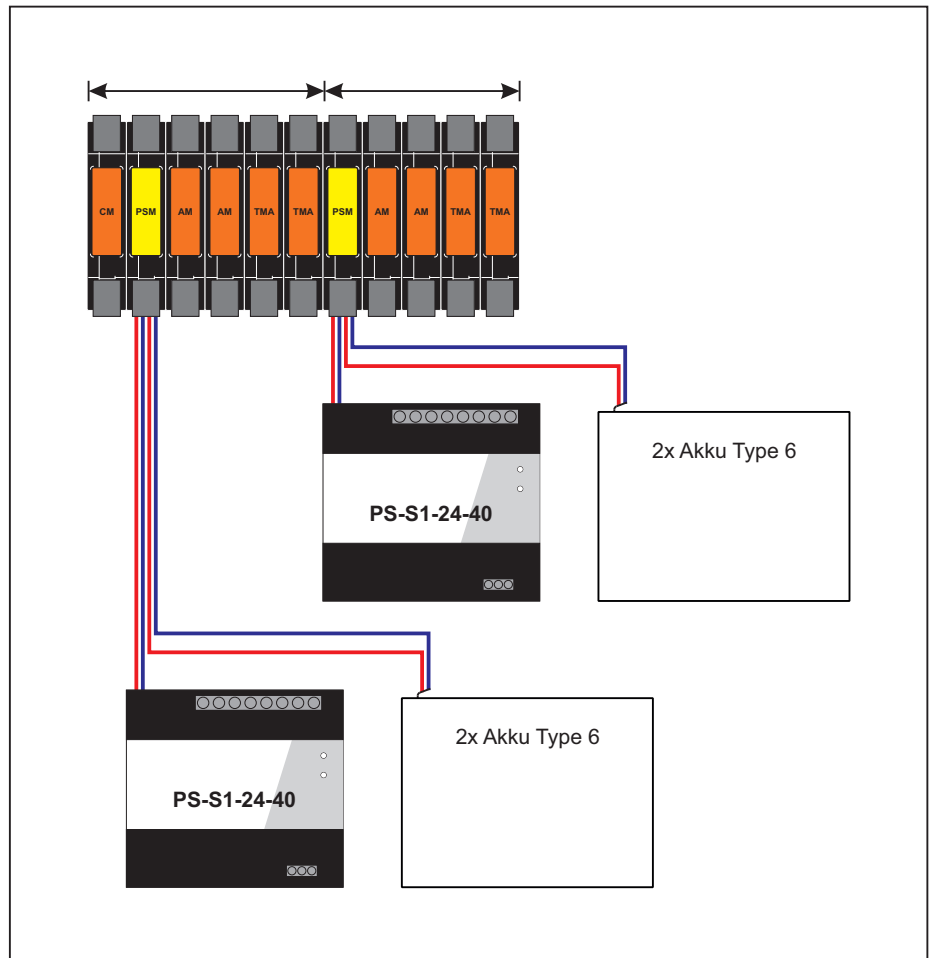

## Installation of the module sockets

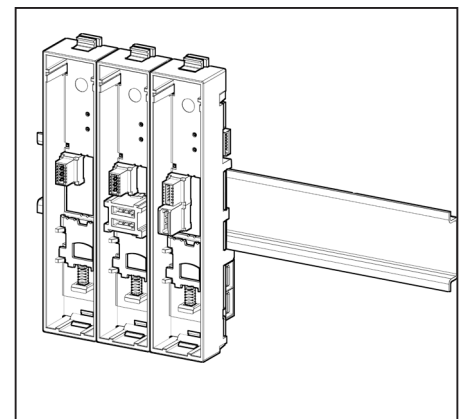
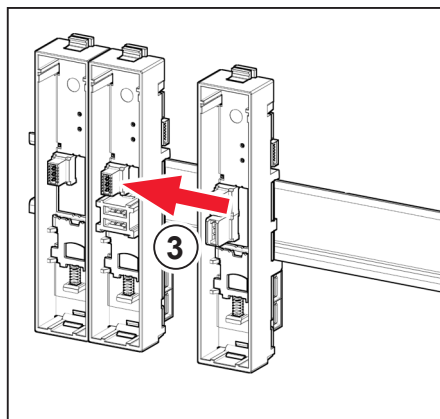
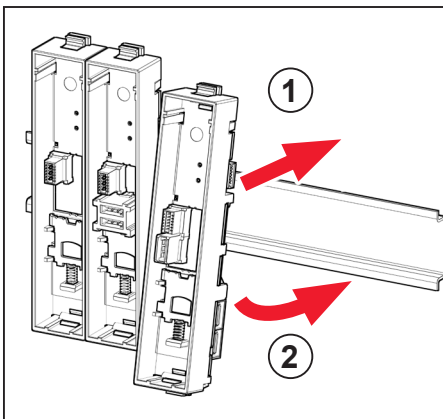

## Removal of the module sockets

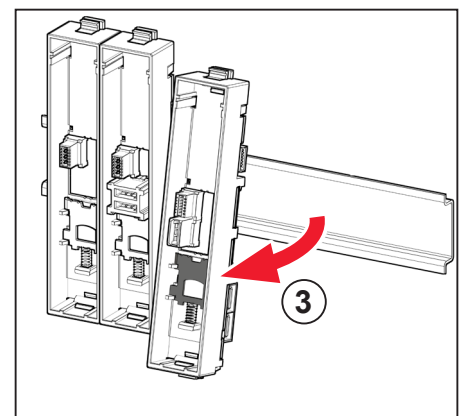
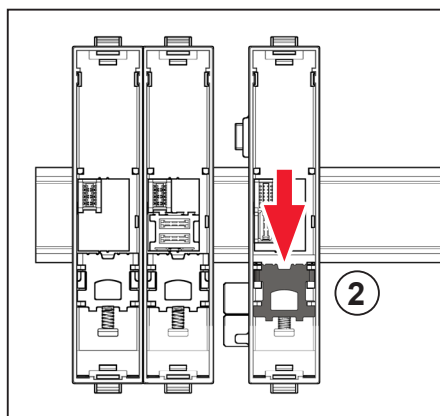
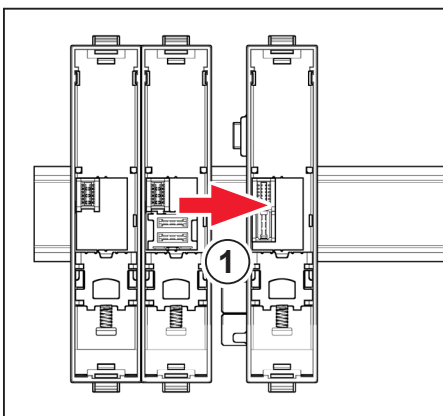

## General instructions for connection

- The connections, particularly the earth connections, may be connected to the respective associated PSM supply module and components only. No cross-flow of current may occur.
- System voltage 24 V DC and/or 230 V AC!
- If 24 V DC and 230 V AC cables are laid in the same cable duct in the control panel, it must be ensured that the **insulation of each conductor must be designed for the highest nominal voltage (≤ 250 V)**.
- A green-yellow core may only be used as protective earth conductor.

## Cables for D+H SHEV systems

When selecting and routing cables, regional installation requirements pertaining to electric cable systems and necessary safety devices, and/or directives pertaining to maintaining the function of electrical cables must be observed (e.g. MLAR guidelines for the fire protection requirements to be met by cable systems in Germany).

### Note:

Due to the variety available on the market, no type designations are specified for these cables. Please contact your D+H Partner for this information.

### Cable line (control panel - detector)

The cables are monitored for short circuits and line breaks.

## Wiring diagram (sample)

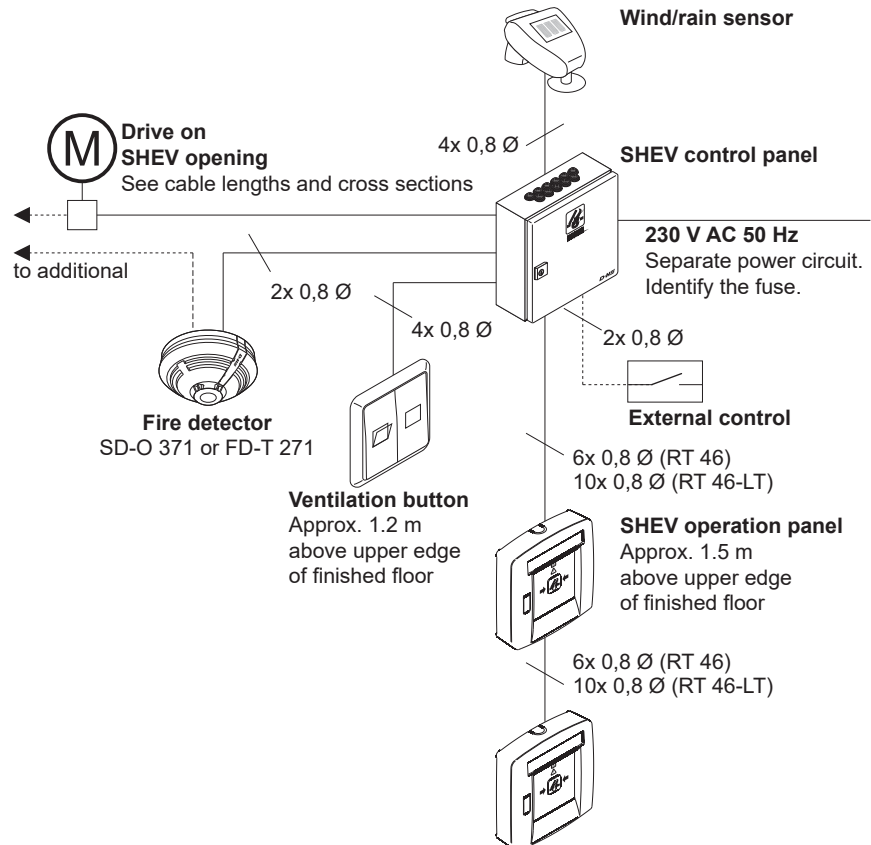

## Cable lengths and cross sections for Mot.a and Mot.b (AM 24 / 24 V drives)

### Cable group (control panel - drive)

#### At least three-wire design:

- **2 wires** for supplying the drive (**Mot.a/ Mot.b**)
- For **pole-changing drives**, **1 additional wire** for cable monitoring, through which the SHEV high-speed (HS) signal is also transmitted to the drive.
- For **ACB drives**, **2 additional wires** for the bus connection.

Total current	1 A	2 A	3 A	4 A	5 A	6 A	7 A	8 A	9 A	10 A	
2 x 1,5 mm <sup>2</sup>	120	60	40	30	24	20	17	15	13	12	m
2 x 2,5 mm <sup>2</sup>	200	100	65	50	40	33	28	25	22	20	m

$$\text{Cross-section (mm}^2\text{)} = \frac{\text{cable length (m)} \times \text{total current}}{80}$$

## Cable lengths and cross sections for L ▲, L ▼, N and PE (AM 230 / 230 V drives)

- max. cable length 500 m
- min. cable cross section 1.5 mm<sup>2</sup>
- A maximum voltage drop of 6.5% (3% with third-party drives) on the cables is permitted.
- Max. 45 drives can be connected to a group
- The following two formulas must always be used to calculate cable cross sections. The higher value must be used.

Total power consumption	200 VA	500 VA	800 VA	1100 VA	1400 VA	1700 VA	1840 VA	
5 x 1,5 mm <sup>2</sup>	167	167	167	132	104	85	79	m
5 x 2,5 mm <sup>2</sup>	278	278	278	220	173	142	131	m
5 x 4 mm <sup>2</sup>	444	444	444	351	276	227	210	m

$$\text{Formula 1: Cross section (mm}^2\text{)} = \frac{\text{Basic cable length (m)} \times \text{total power of all Drives (VA)}}{96600}$$

$$\text{Formula 2: Cross section (mm}^2\text{)} = \frac{\text{Basic cable length (m)}}{111}$$

## Connection – PSM

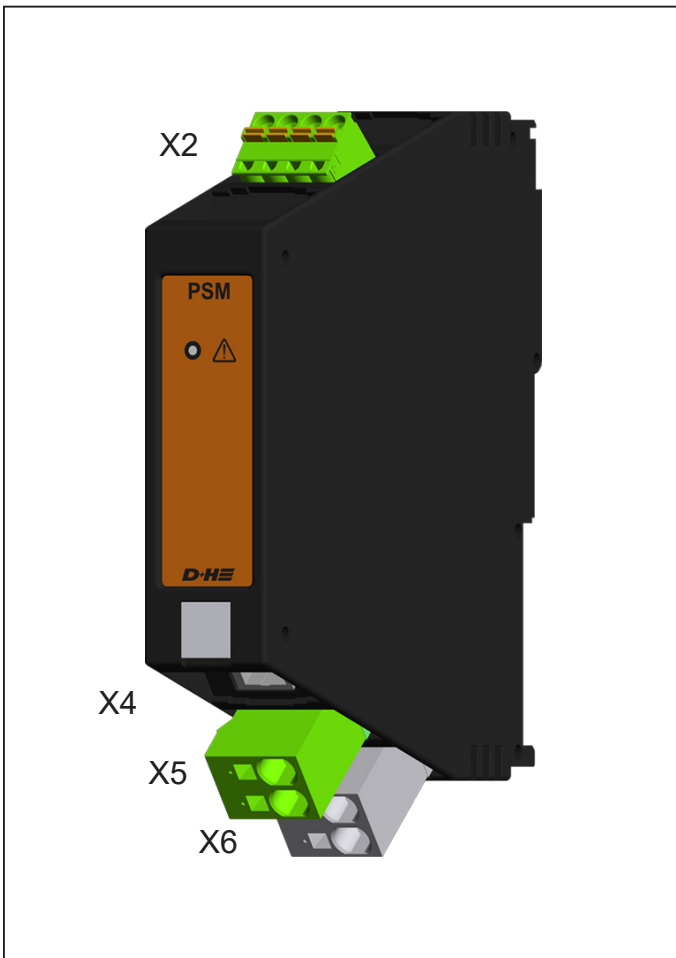

No.	Name	Description
X2.1	N+	Output potential without an emergency supply for ventilation functions, max. 500 mA
X2.2	-	Reference potential (do not connect to P-)
X2.3	+	Output potential with an emergency supply, max. 500 mA
X2.4	-	Reference potential (do not connect to P-)
X4	TCSU1	RJ12 connection of external battery temperature sensor
X5.1	BATT+	Secondary power supply (battery), max 40 A
X5.2	BATT-	
X6.1	SNT+	Primary power supply (power pack), max 40 A
X6.2	SNT-	

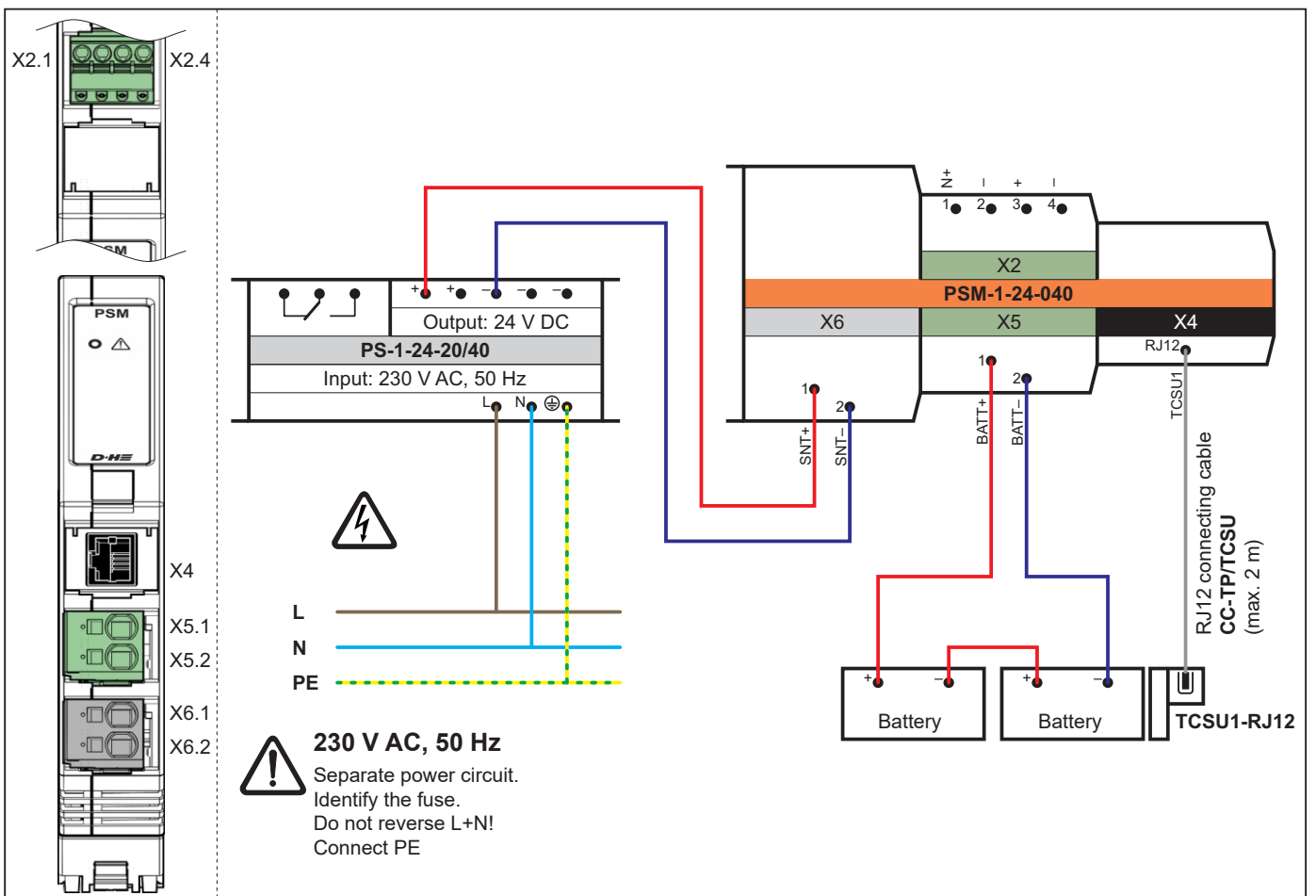

# Connection – CM / CM-B

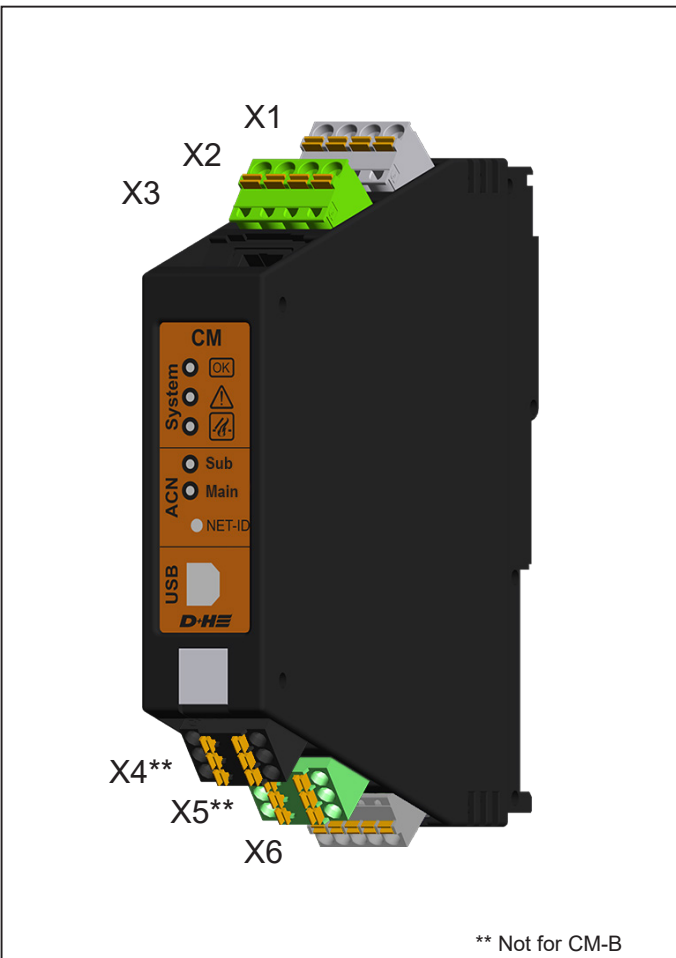

No.	Name	Description
X1.1	n.c.	n.c.
X1.2	NO 1	Isolated change-over contact, max. 35 V / 1 A, collective alarm (factory setting, can be programmed using SCS)
X1.3	COM 1	
X1.3	NC 1	
X2.1	n.c.	n.c.
X2.2	NO 2	Isolated change-over contact, max. 35 V / 1 A, general malfunction (factory setting, can be programmed using SCS)
X2.3	COM 2	
X2.4	NC 2	
X3	TP-C1	RJ12 connection for touch panel
X4.1	Shield	AdComNet main interface **
X4.2	ACN D-	
X4.3	ACN D+	
X5.1	Shield	AdComNet sub interface **
X5.2	ACN D-	
X5.3	ACN D+	
X6.5	n.c.	n.c.
X6.4	DI 1.2	Freely configurable digital input, 0 to 28 V, active minus or plus, control panel OPEN (factory setting, can be programmed using SCS)
X6.3	DI 1.3	
X6.2	DI 1.4	Freely configurable digital input, 0 to 28 V, active minus or plus
X6.1	-	
X6.1	-	Reference potential (do not connect to P-)

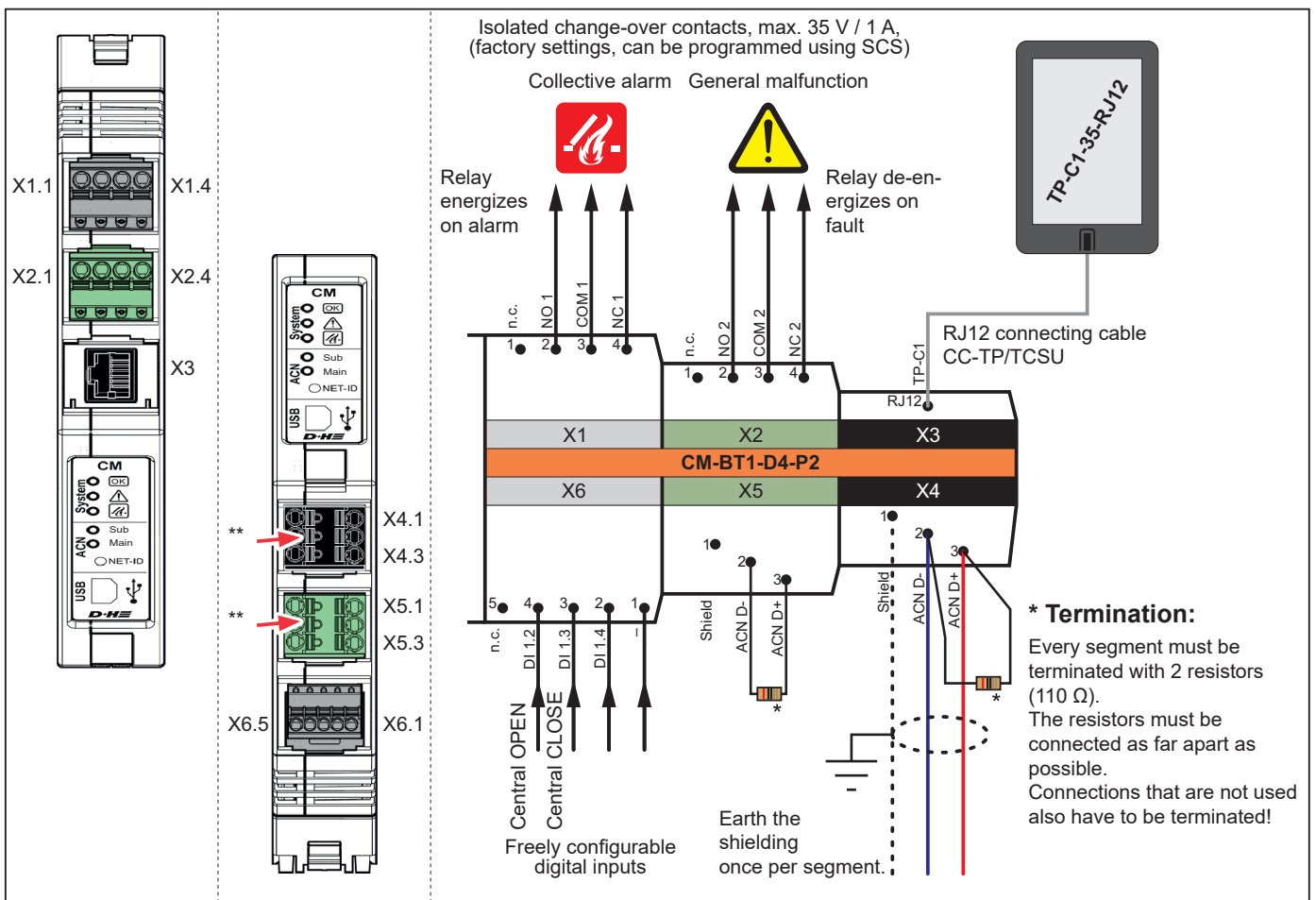

## Connection – Digital inputs and outputs

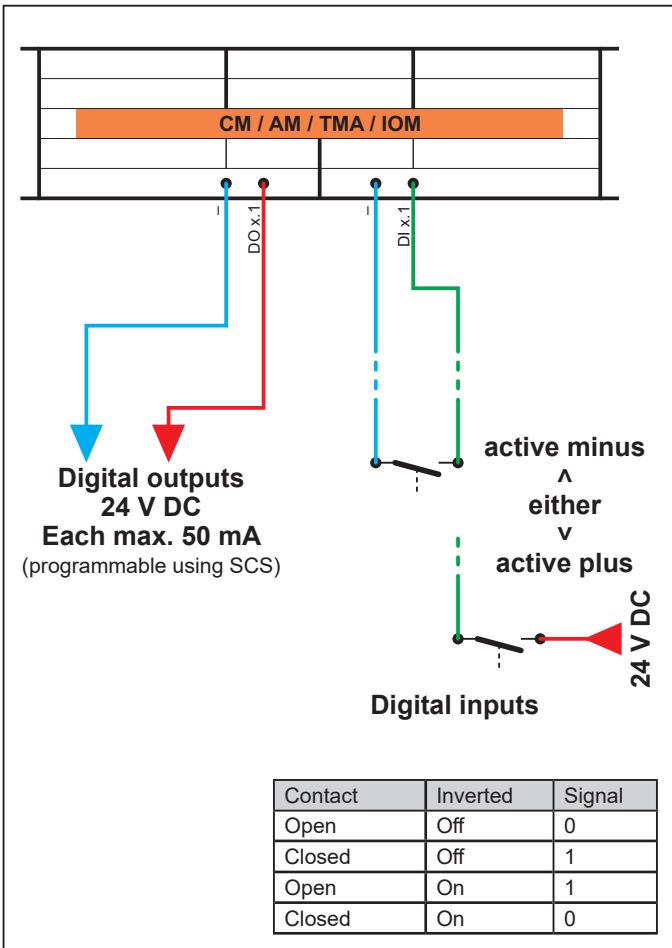

## Battery for the clock of the event memory

The CM module has a built-in lithium battery on the underside, which buffers the internal clock of the event memory in the event of a power failure.

The battery should be replaced at least every 10 years.

**Attention! Folgende Reihenfolge beachten:**

1. Read out and save existing parameterization
2. Change battery. Battery type: Lithium cell CR1216
3. Read in parameterization again

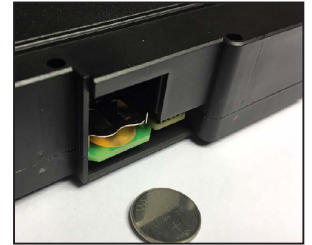
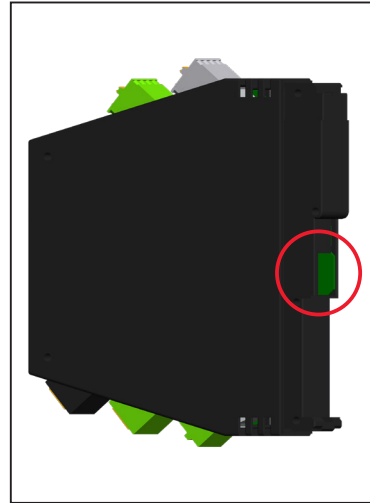

## Further top hat rail levels for additional CPS-M modules (Not for CM-B)

If a top-hat rail is not sufficient for the configuration of your system, a further top-hat rails can be integrated in the following way.

Further top-hat rail rows are assembled like the first row of the CPS-M (see « Arrangement of the modules » page 9 )

Connect the AdComNet main interface X4 on the CM module of the first row to the AdComNet sub interface X5 on the CM module of the additional row. If you need additional module rows, proceed in the same way.

You can connect to any CM via USB and use the connected rows as a common control panel.

LT inputs, lines and groups can be freely linked across all rows.

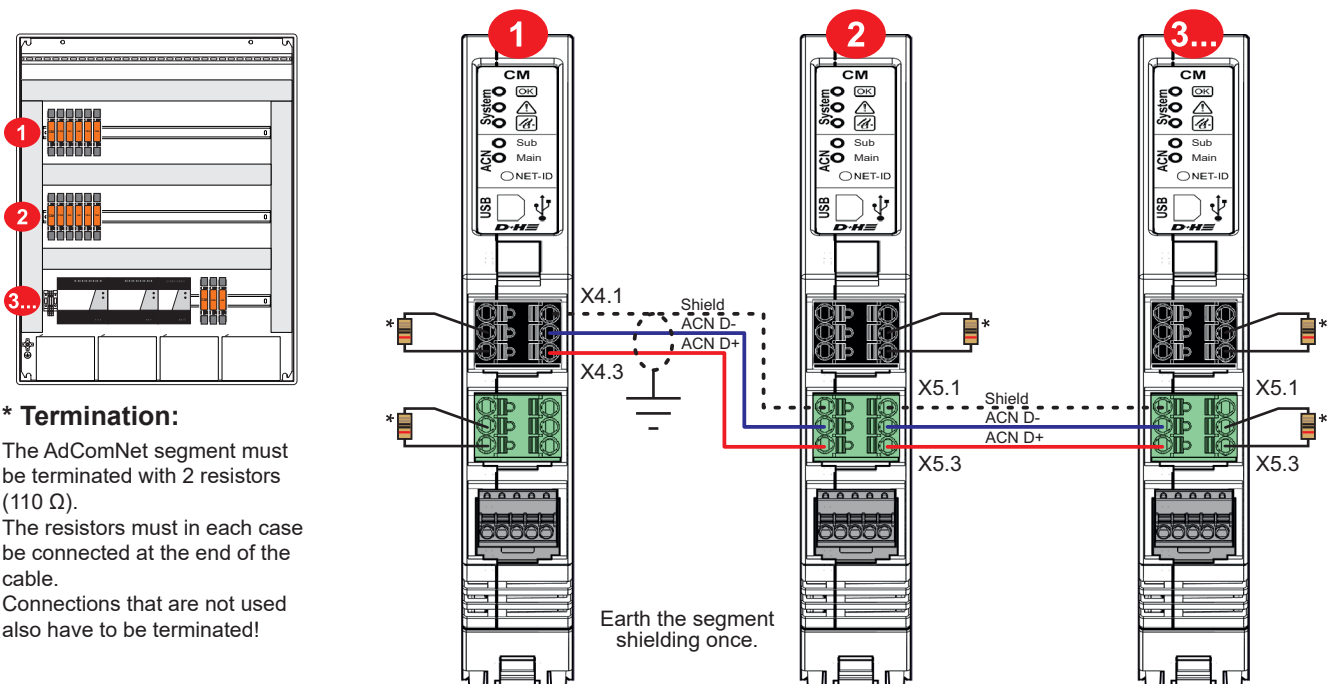

# Connection – IOM

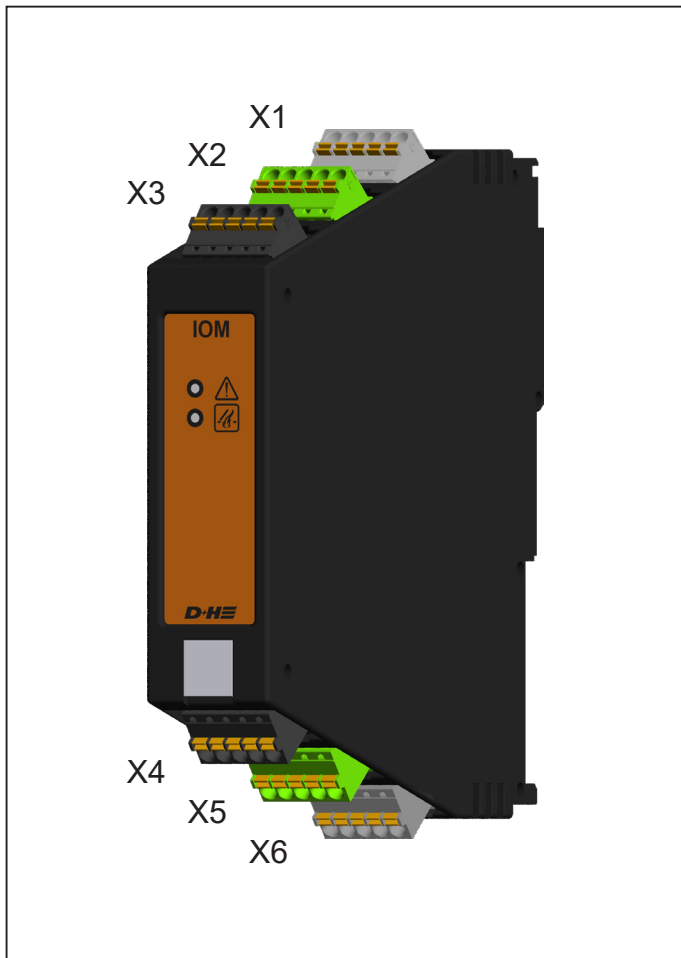

No.	Name	Description
X1.1	DO 1.4	freely configurable digital output 1.4 *
X1.2	DO 1.3	freely configurable digital output 1.3 *
X1.3	-	Reference potential (do not connect to P-)
X1.4	DO 1.2	freely configurable digital output 1.2 *
X1.5	DO 1.1	freely configurable digital output 1.1 *
X2.1	DO 2.4	freely configurable digital output 2.4 *
X2.2	DO 2.3	freely configurable digital output 2.3 *
X2.3	-	Reference potential (do not connect to P-)
X2.4	DO 2.2	freely configurable digital output 2.2 *
X2.5	DO 2.1	freely configurable digital output 2.1 *
X3.1	DO 3.4	freely configurable digital output 3.4 *
X3.2	DO 3.3	freely configurable digital output 3.3 *
X3.3	-	Reference potential (do not connect to P-)
X3.4	DO 3.2	freely configurable digital output 3.2 *
X3.5	DO 3.1	freely configurable digital output 3.1 *
X4.5	DI 1.1	freely configurable digital input 1.1 **
X4.4	DI 1.2	freely configurable digital input 1.2 **
X4.3	-	Reference potential (do not connect to P-)
X4.2	DI 1.3	freely configurable digital input 1.3 **
X4.1	DI 1.4	freely configurable digital input 1.4 **
X5.5	DI 2.1	freely configurable digital input 2.1 **
X5.4	DI 2.2	freely configurable digital input 2.2 **
X5.3	-	Reference potential (do not connect to P-)
X5.2	DI 2.3	freely configurable digital input 2.3 **
X5.1	DI 2.4	freely configurable digital input 2.4 **
X6.5	DI 3.1	freely configurable digital input 3.1 **
X6.4	DI 3.2	freely configurable digital input 3.2 **
X6.3	-	Reference potential (do not connect to P-)
X6.2	DI 3.3	freely configurable digital input 3.3 **
X6.1	DI 3.4	freely configurable digital input 3.4 **

\* max. 50 mA, short-circuit-proof  
 \*\* 0 ... 28 V, active minus or plus (not galvanically isolated)

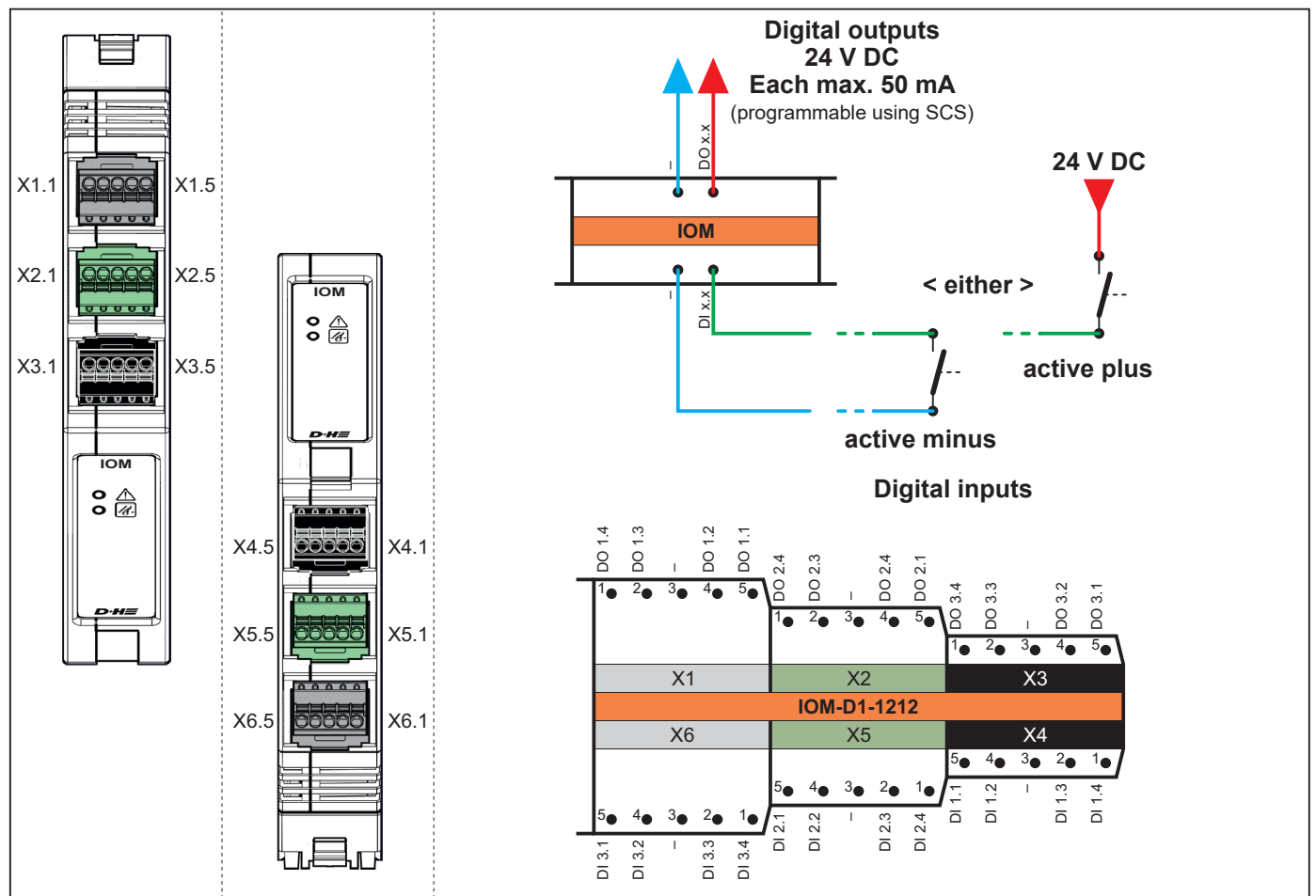

## Connection – BRM

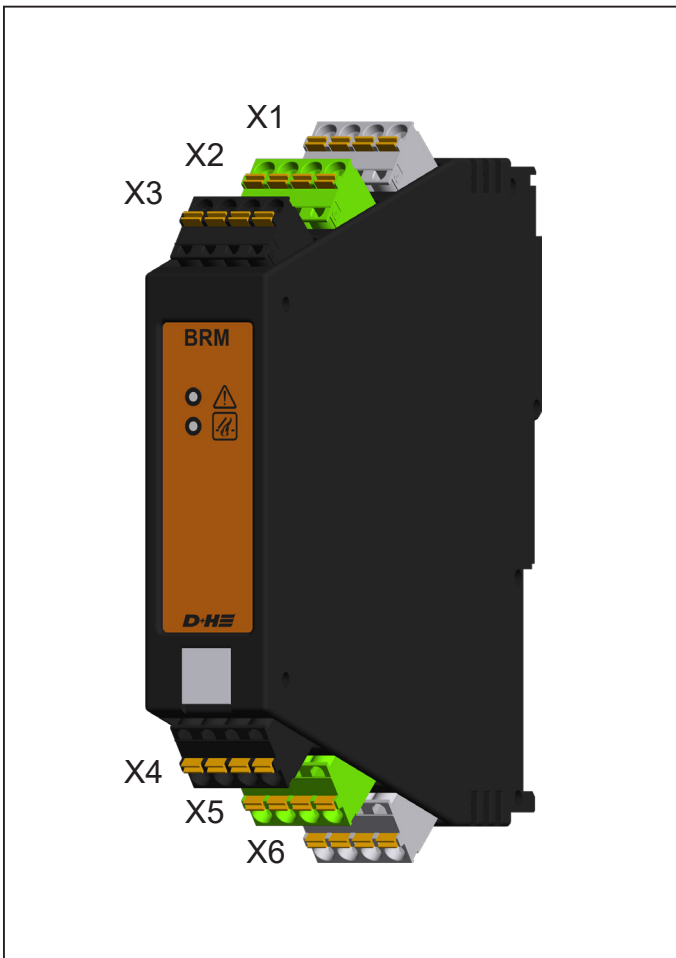

No.	Name	Description
X1.1	NC 1	Floating output 1 - normally closed *
X1.2	COM 1	Floating output 1 – COM
X1.3	NO 1	Floating output 1 – normally open *
X1.4	COM 1	Floating output 1 – COM
X2.1	NC 2	Floating output 2 – normally closed *
X2.2	COM 2	Floating output 2 – COM
X2.3	NO 2	Floating output 2 – normally open *
X2.4	COM 2	Floating output 2 – COM
X3.1	NC 3	Floating output 3 – normally closed *
X3.2	COM 3	Floating output 3 – COM
X3.3	NO 3	Floating output 3 – normally open *
X3.4	COM 3	Floating output 3 – COM
X4.4	COM 4	Floating output 4 – COM
X4.3	NO 4	Floating output 4 – normally open *
X4.2	COM 4	Floating output 4 – COM
X4.1	NC 4	Floating output 4 – normally closed *
X5.4	COM 5	Floating output 5 – COM
X5.3	NO 5	Floating output 5 – normally open *
X5.2	COM 5	Floating output 5 – COM
X5.1	NC 5	Floating output 5 – normally closed *
X6.4	COM 6	Floating output 6 – COM
X6.3	NO 6	Floating output 6 – normally open *
X6.2	COM 6	Floating output 6 – COM
X6.1	NC 6	Floating output 6 – normally closed *

\* 5 ... 30 V DC, 10 mA ... 3 A / 5 ... 265 V AC, 10 mA ... 3 A, cos φ = 1

The "Failsafe power failure" parameter can be used to define the state of the potential-free contact to be taken in the event of a failure of the mains and battery supply. If the "None" configuration is selected, the last status is retained.

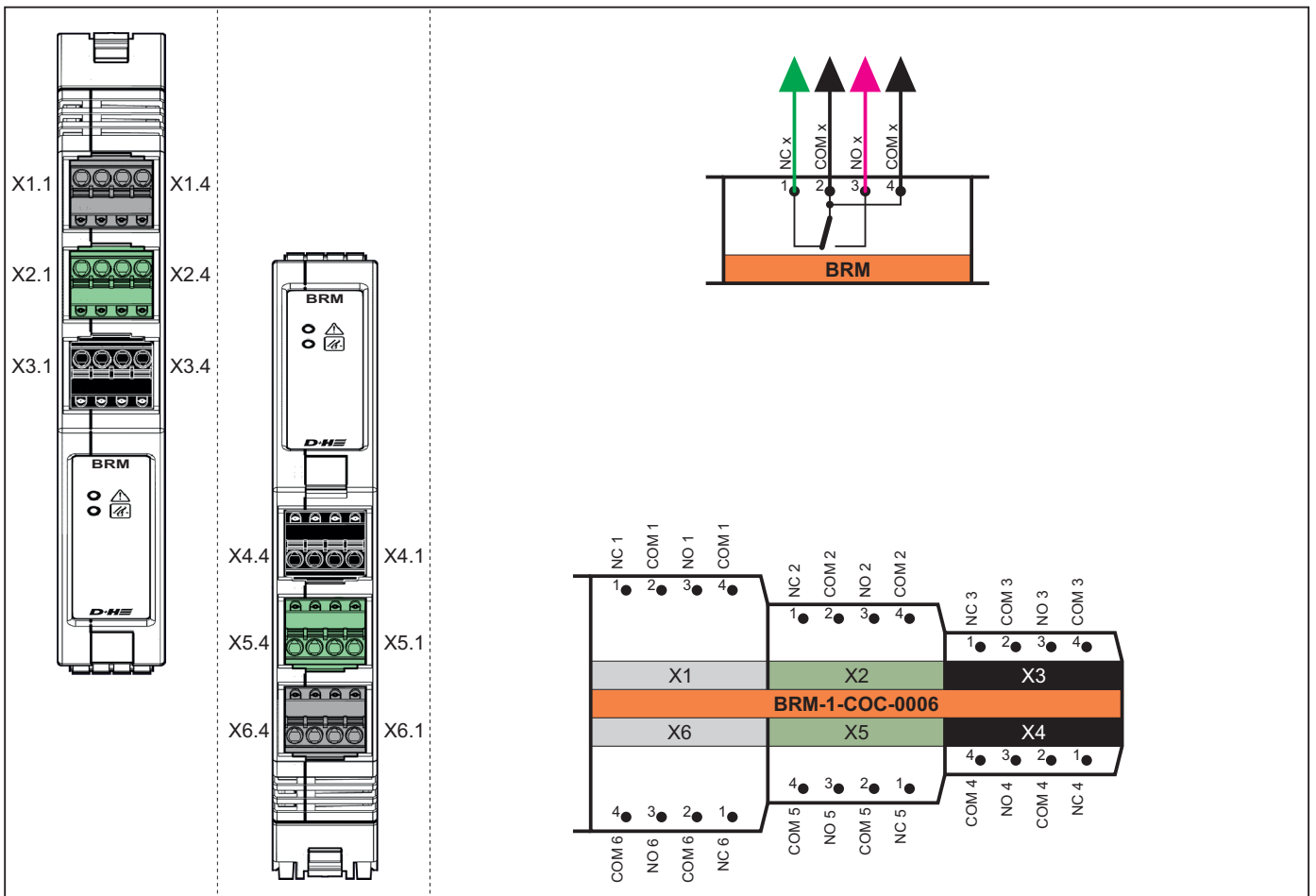

## Connection – ADM

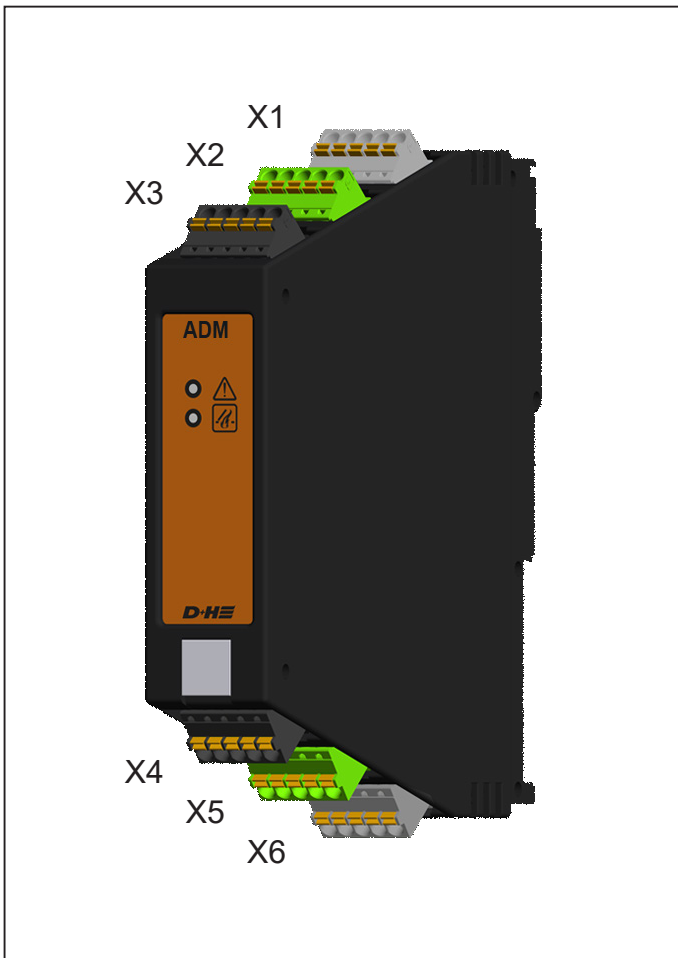

No.	Name	Description
X1.1	DO 1.4	freely configurable digital output 1.4 max. 50 mA, short-circuit-proof
X1.2	DO 1.3	freely configurable digital output 1.3 max. 50 mA, short-circuit-proof
X1.3	-	Reference potential (do not connect to P-)
X1.4	DO 1.2	freely configurable digital output 1.2 max. 50 mA, short-circuit-proof
X1.5	DO 1.1	freely configurable digital output 1.1 max. 50 mA, short-circuit-proof
X2.1	DO 2.4	freely configurable digital output 2.4 max. 50 mA, short-circuit-proof
X2.2	DO 2.3	freely configurable digital output 2.3 max. 50 mA, short-circuit-proof
X2.3	-	Reference potential (do not connect to P-)
X2.4	DO 2.2	freely configurable digital output 2.2 max. 50 mA, short-circuit-proof
X2.5	DO 2.1	freely configurable digital output 2.1 max. 50 mA, short-circuit-proof
X3.1	DO 3.4	freely configurable digital output 3.4 max. 50 mA, short-circuit-proof
X3.2	DO 3.3	freely configurable digital output 3.3 max. 50 mA, short-circuit-proof
X3.3	-	Reference potential (do not connect to P-)
X3.4	DO 3.2	freely configurable digital output 3.2 max. 50 mA, short-circuit-proof
X3.5	DO 3.1	freely configurable digital output 3.1 max. 50 mA, short-circuit-proof
X4.5	DI/AI 1.1	freely configurable multifunctional input 1.1 * digital 0 ... 28 V, active minus or plus analog 0 ... 10 V
X4.4	DI/AI 1.2	freely configurable multifunctional input 1.2 * digital 0 ... 28 V, active minus or plus analog 0 ... 10 V
X4.3	-	Reference potential (do not connect to P-)
X4.2	DI/AI 1.3	freely configurable multifunctional input 1.3 * digital 0 ... 28 V, active minus or plus analog 0 ... 10 V
X4.1	DI/AI 1.4	freely configurable multifunctional input 1.4 * digital 0 ... 28 V, active minus or plus analog 0 ... 10 V
X5.5	DI 2.1	freely configurable digital input 2.1 * digital 0 ... 28 V, active minus or plus
X5.4	DI 2.2	freely configurable digital input 2.2 * digital 0 ... 28 V, active minus or plus
X5.3	-	Reference potential (do not connect to P-)
X5.2	DI 2.3	freely configurable digital input 2.3 * digital 0 ... 28 V, active minus or plus
X5.1	DI 2.4	freely configurable digital input 2.4 * digital 0 ... 28 V, active minus or plus
X6.5	DI 3.1	freely configurable digital input 3.1 * digital 0 ... 28 V, active minus or plus
X6.4	DI 3.2	freely configurable digital input 3.2 * digital 0 ... 28 V, active minus or plus
X6.3	-	Reference potential (do not connect to P-)
X6.2	DI 3.3	freely configurable digital input 3.3 * digital 0 ... 28 V, active minus or plus
X6.1	DI 3.4	freely configurable digital input 3.4 * digital 0 ... 28 V, active minus or plus

\* not galvanically isolated

# Connection – ADM

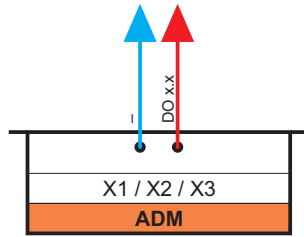

**Digitale Ausgänge 24 V DC je max. 50 mA**  
 (Programmierbar über SCS)  
**Digital outputs 24 V DC each max. 50 mA**  
 (programmable using SCS)

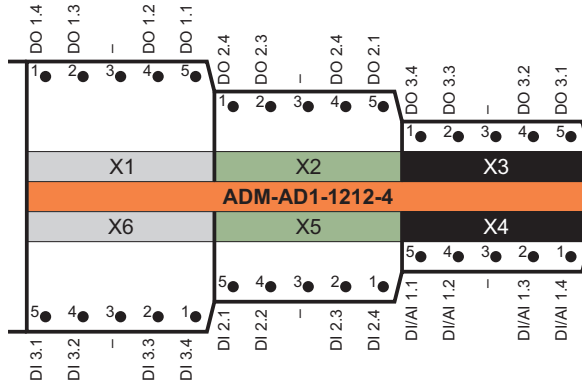
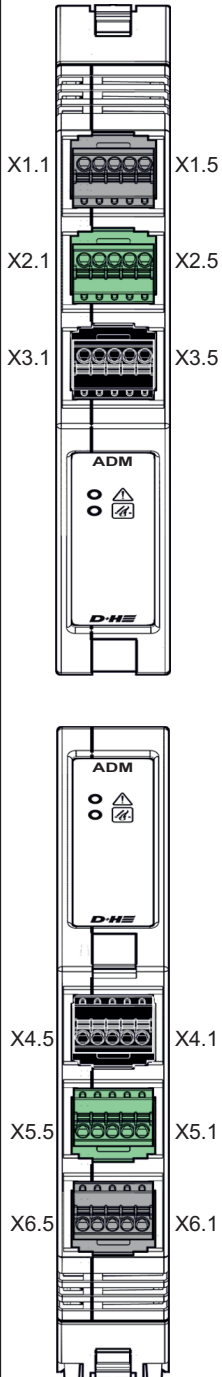

**Multifunctional inputs**  
 (programmable using SCS)

**Digital:**

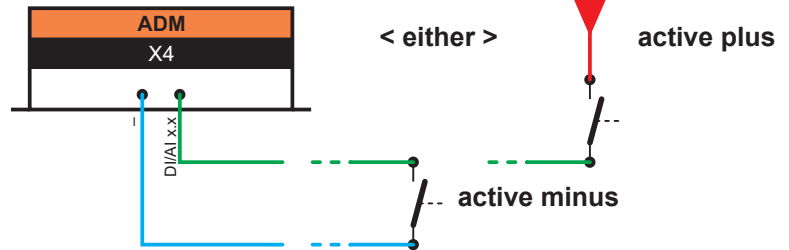

**Analog:**

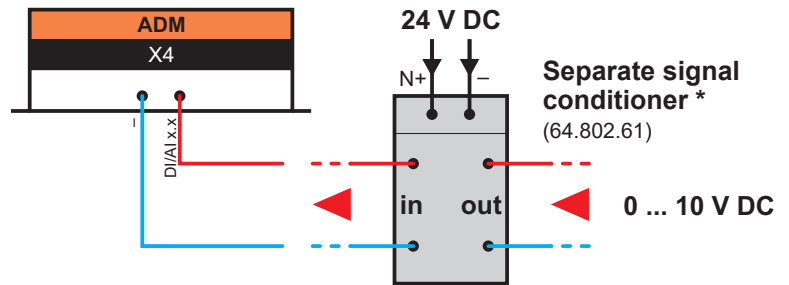

**Digital inputs**

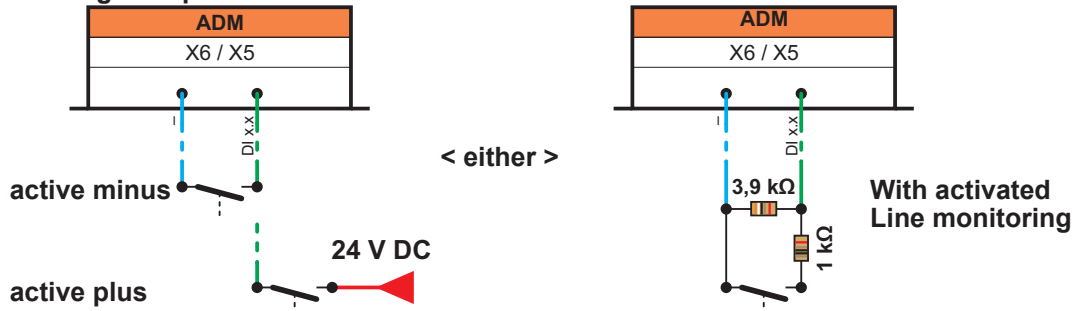

\* Without a separate signal conditioner there is no galvanic isolation.  
 Sensors supplied by the CPS-M do not require an signal conditioner.

## Connection – AM 24 / AM-B 24

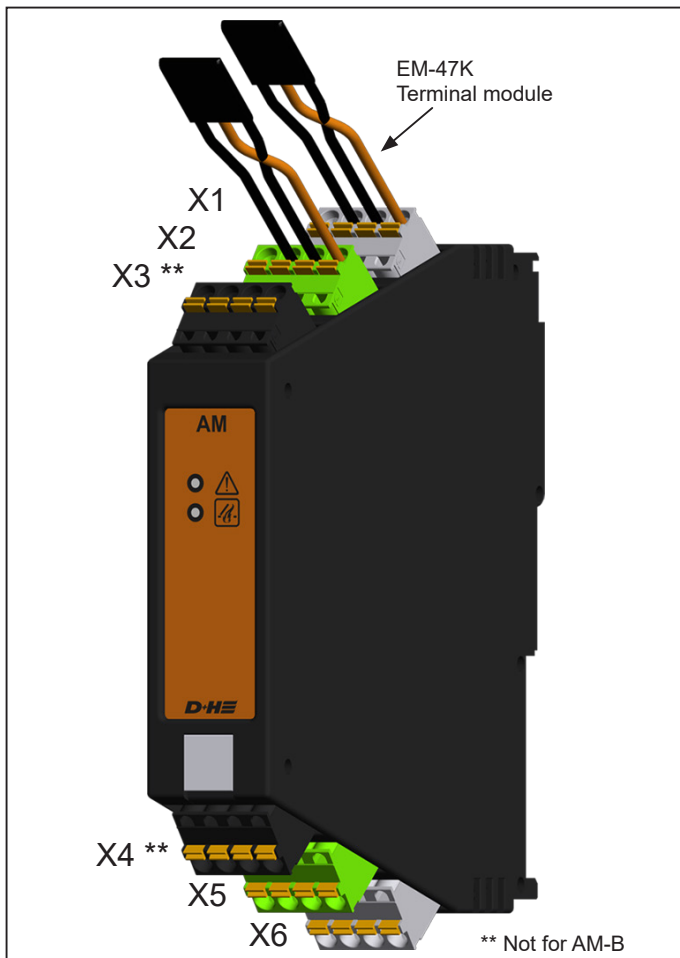

No.	Name	Description
X1.1	P-	Reference potential, max. 10 A (do not connect to -)
X1.2	MOT.b 1	Drive group 1, max. 10 A
X1.3	MOT.a 1	
X1.4	E/HS 1	Monitoring wire / high-speed for actuator group 1
X2.1	P-	Reference potential, max. 10 A (do not connect to -)
X2.2	MOT.b 2	Drive group 2, max. 10 A
X2.3	MOT.a 2	
X2.4	E/HS 2	Monitoring wire / high-speed for actuator group 2
X3.1	ACB.B 1	ACB interface of drive group 1
X3.2	ACB.A 1	
X3.3	ACB.B 2	ACB interface of drive group 2
X3.4	ACB.A 2	
X4.4	SGI 1	Position transmitter for drive group 1 (not yet implemented)
X4.3	-	Reference potential (do not connect to P-)
X4.2	SGI 2	Position transmitter for drive group 2 (not yet implemented)
X4.1	-	Reference potential (do not connect to P-)
X5.4	DO 2.1	Freely configurable digital output 1.1, max. 50 mA / NOT CLOSED signal LT 2
X5.3	-	Reference potential (do not connect to P-)
X5.2	DI 2.1	Freely configurable digital input, 0 to 28 V, active minus or plus / OPEN LT 2
X5.1	DI 2.2	Freely configurable digital input, 0 to 28 V, active minus or plus / CLOSE LT 2
X6.4	DO 1.1	Freely configurable digital output 2.1, max. 50 mA / NOT CLOSED signal LT 1
X6.3	-	Reference potential (do not connect to P-)
X6.2	DI 1.1	Freely configurable digital input, 0 to 28 V, active minus or plus / OPEN LT 1
X6.1	DI 1.2	Freely configurable digital input, 0 to 28 V, active minus or plus / CLOSE LT 1

## Connection – Vent buttons to AM 24 / AM-B 24

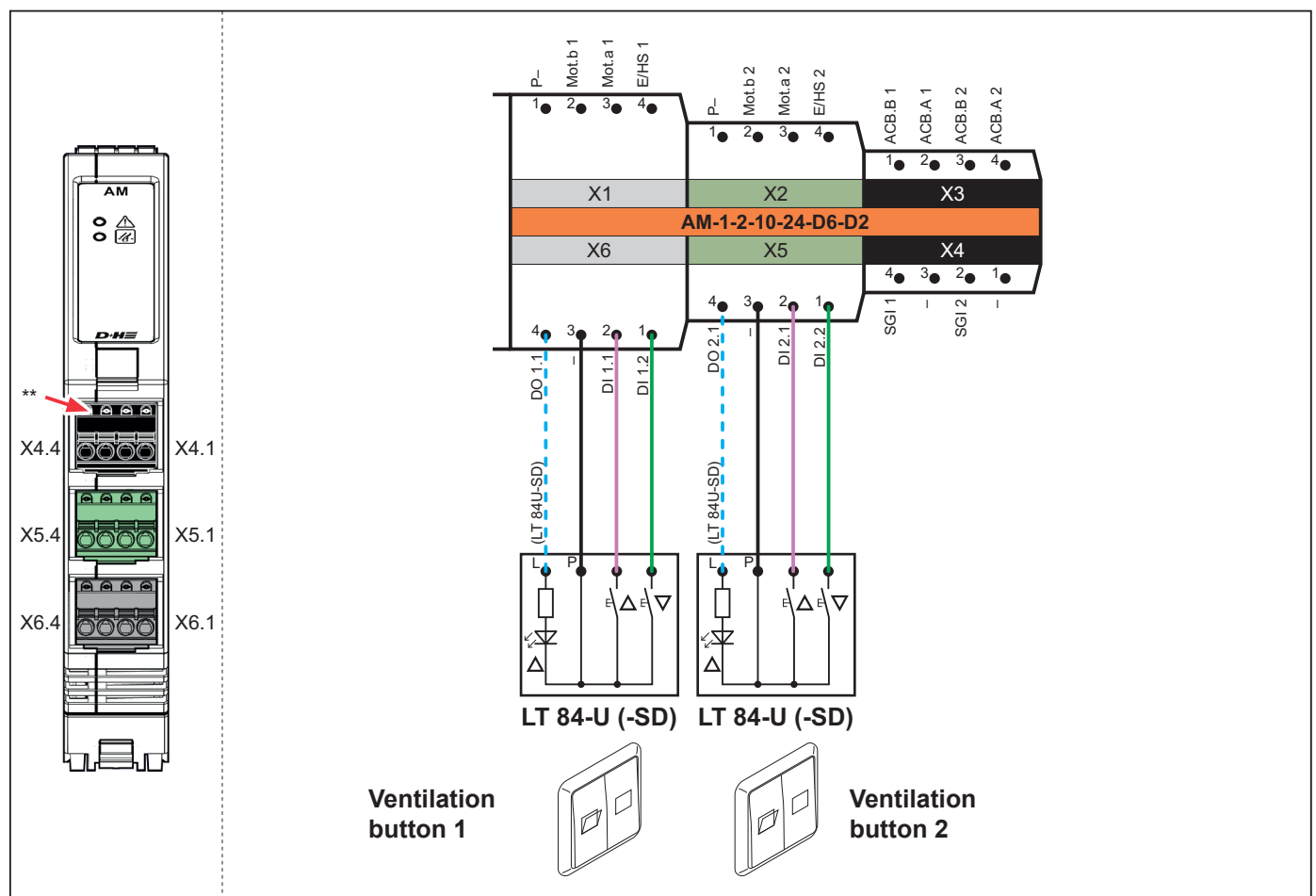

## Connection – AM 24 with ACB drives

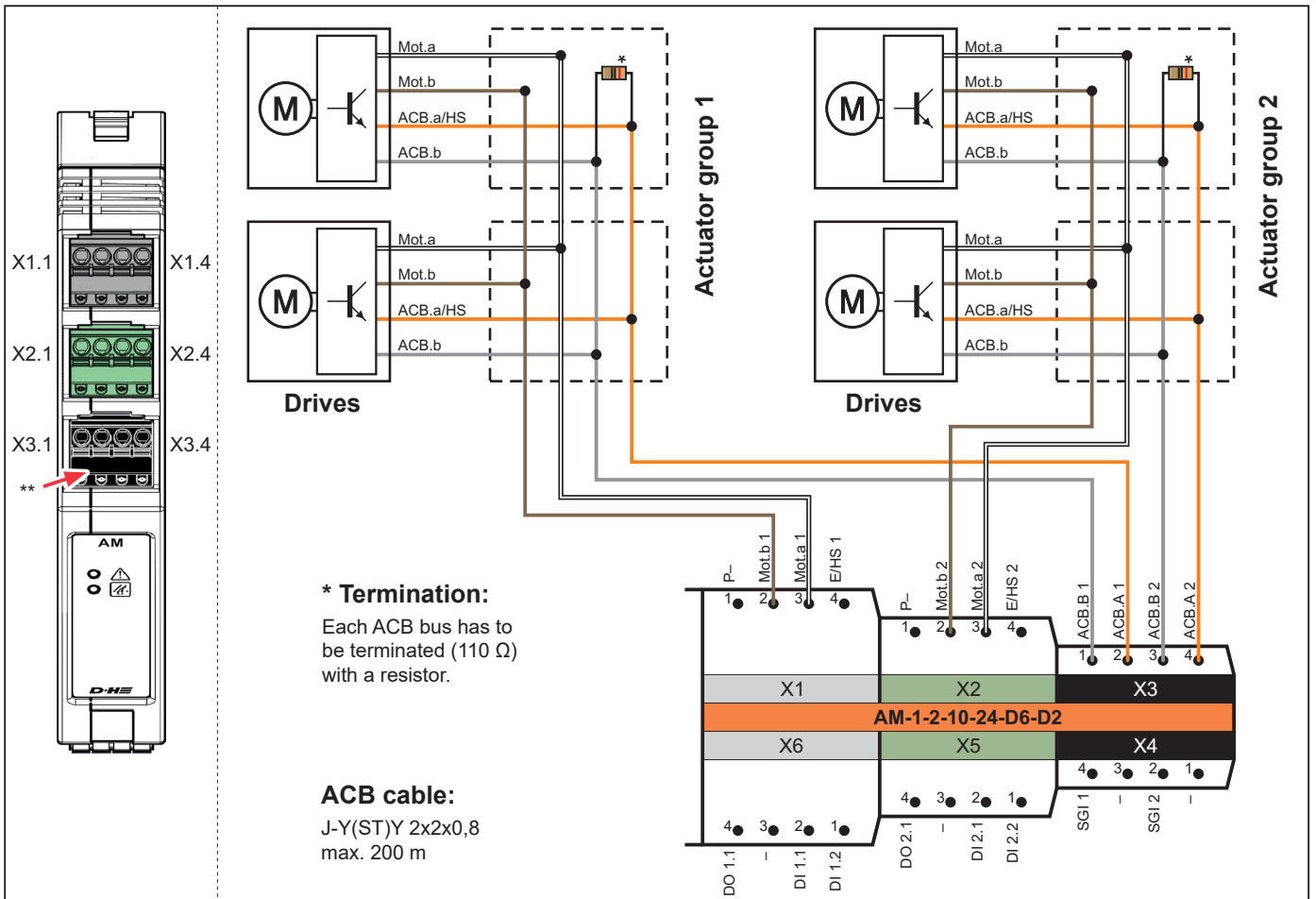

## Connection – AM 24 / AM-B 24 with pole-changing drives

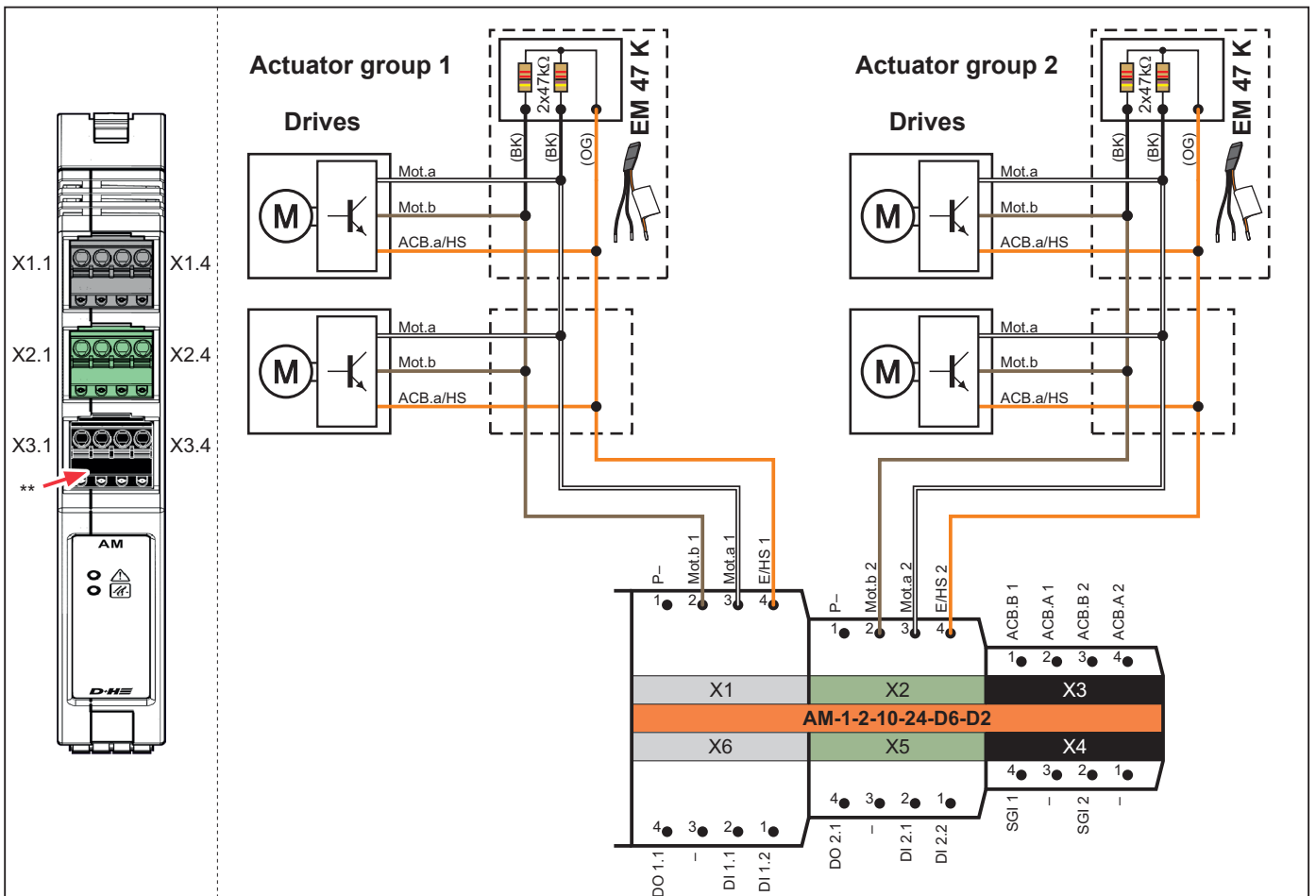

## Connection – AM 230

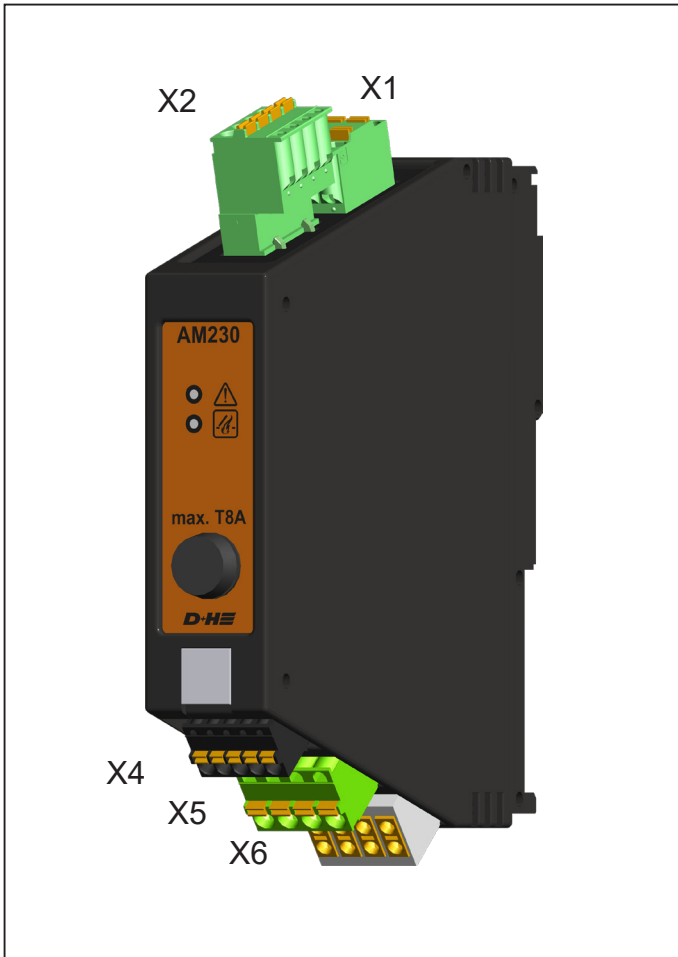

No.	Name	Description
X1.1	N	Neutral conductor input
X1.2	L	Phase 230 V input
X2.1	N	Neutral conductor output
X2.2	L-OPEN	Phase 230 V OPEN direction output
X2.3	L-CLOSE	Phase 230 V CLOSE direction output
X2.4	E	Monitoring wire
X4.5	-	Reference potential (do not connect to P-)
X4.4	ACB +	Supply of the ACB interface
X4.3	ACB.A	ACB interface of drive group
X4.2	ACB.B	
X4.1	SGI	Position transmitter for drive group (not yet implemented)
X5.4	DO 1.1	Freely configurable digital output 1.1, max. 50 mA / NOT CLOSED signal LT
X5.3	-	Reference potential (do not connect to P-)
X5.2	DI 1.1	Freely configurable digital input 1.1, 0 to 28 V, active minus or plus / OPEN LT
X5.1	DI 1.2	Freely configurable digital input 1.2, 0 to 28 V, active minus or plus / CLOSE LT
X6.4	-	Reference potential (do not connect to P-)
X6.3	FES	Fault NSV
X6.2	-	Reference potential (do not connect to P-)
X6.1	SES	Start NSV, max. 50 mA

### Please Note:

If the AM 230 is used as a pure ventilation group, the line monitoring can be switched off. In this case, no EM 230 end module is required.

## Connection – NSV 401 control and vent button to AM 230



## Connection – NSV 401 power supply and D+H ACB drives

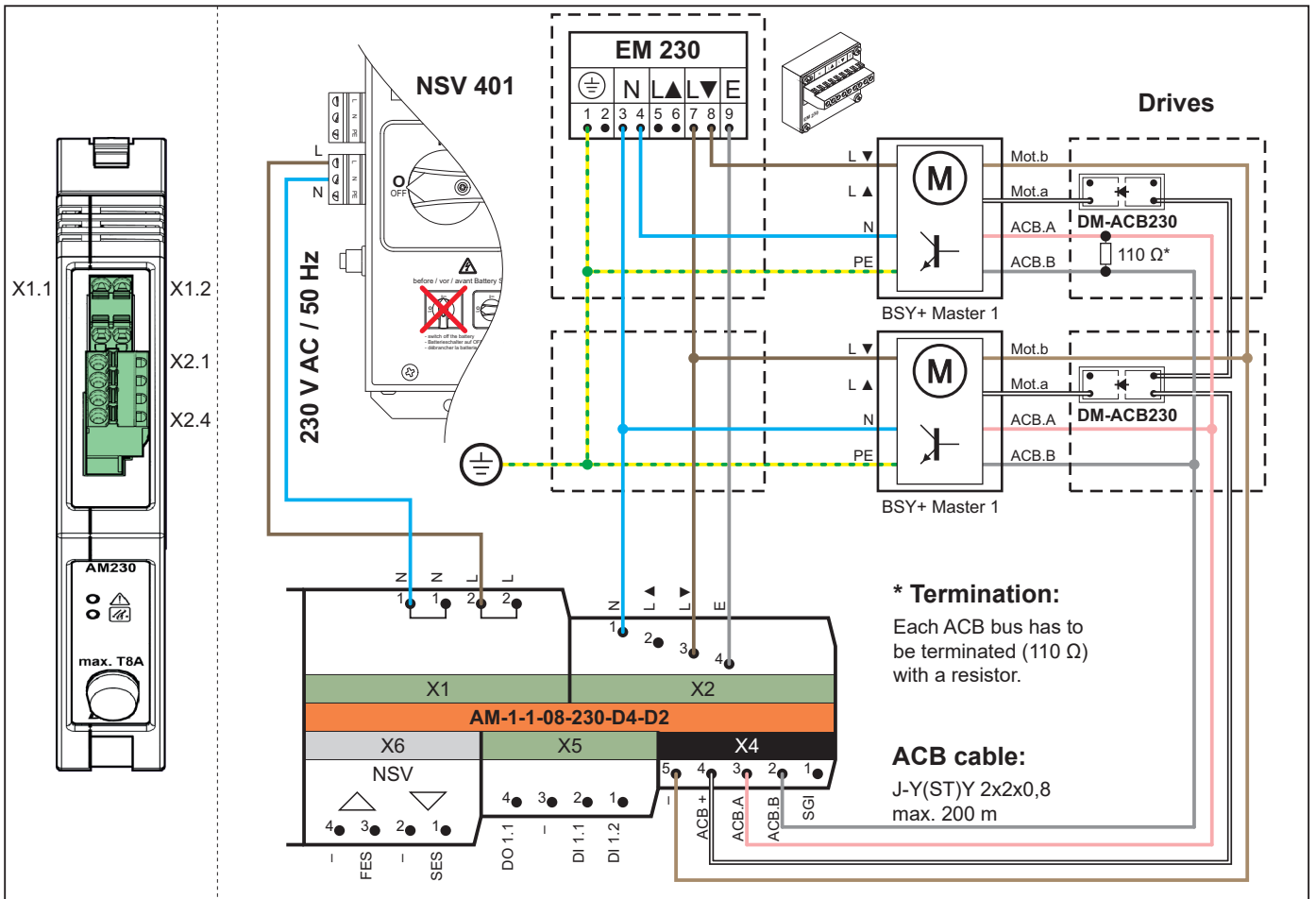

## Connection – NSV 401 power supply and D+H drives

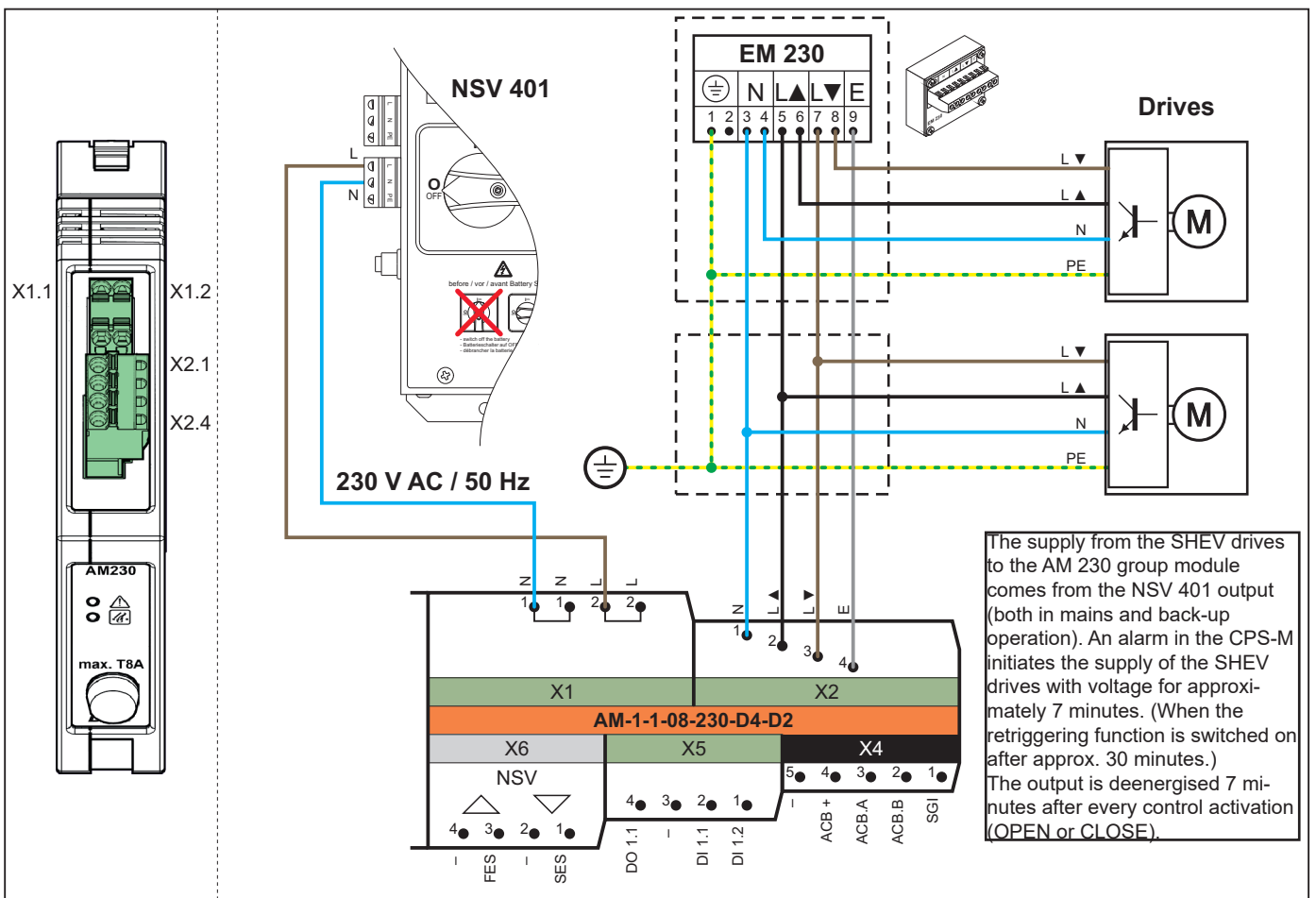



## Connection – TMA

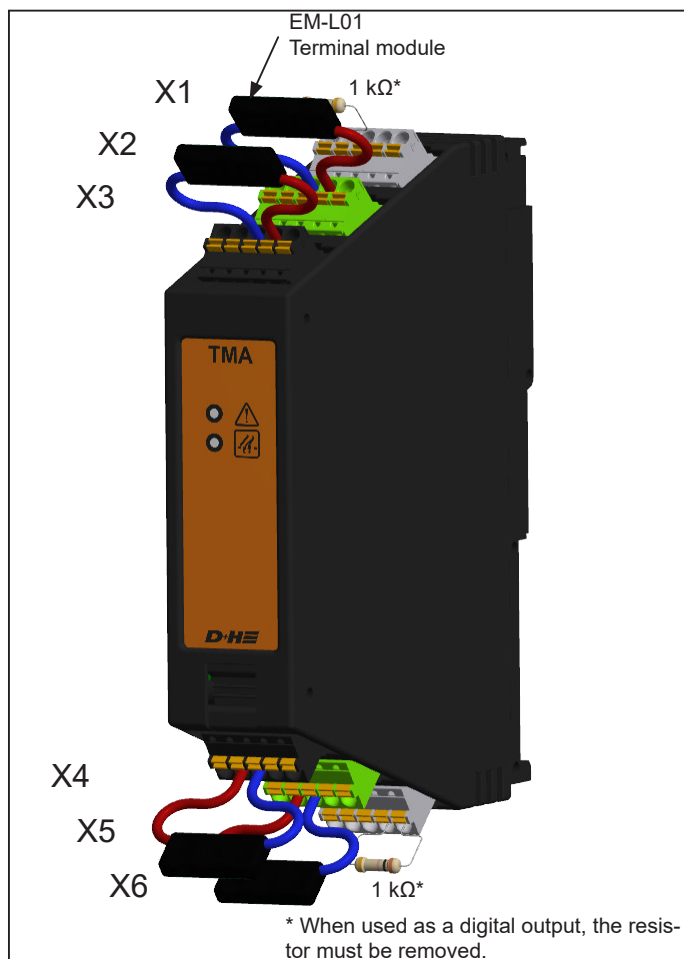

No.	Name	Description (as RM/RT lines)	
X1.1	DO 2.3	Placeholder for FAS resistor	RT line 1
X1.2	DO 2.2	Placeholder for FAS resistor	
X1.3	-	Reference potential (do not connect to P-)	
X1.4	DO 1.3 (S)	Fault output (RT line 1), max. 50 mA	
X1.5	DO 1.2 (A)	Alarm output (RT line 1), max. 50 mA	
X2.1	DO 1.1 (K)	Monitoring output (RT line 1), max. 50 mA	RT line 1
X2.2	DI 1.1 (Z)	Reset input (RT line 1)	
X2.3	-	Reference potential (do not connect to P-)	
X2.4	LINIE 1 (T)	RT line 1, max. 50 mA	
X2.5	FE	Functional earth	
X3.1	DO 2.1	No function	RM line 1
X3.2	DI 2.1	No function / Reset input fire alarm system	
X3.3	-	Reference potential (do not connect to P-)	
X3.4	LINIE 2 (R)	RM line 1, max. 50 mA	
X3.5	FE	Functional earth	
X4.5	FE	Functional earth	RM line 2
X4.4	LINIE 3 (R)	RM line 2, max. 50 mA	
X4.3	-	Reference potential (do not connect to P-)	
X4.2	DI 3.1	No function	
X4.1	DO 3.1	No function	
X5.5	FE	Functional earth	RT line 2
X5.4	LINIE 4 (T)	RT Line 2	
X5.3	-	Reference potential (do not connect to P-)	
X5.2	DI 4.1 (Z)	Reset input (RT line 2)	
X5.1	DO 4.1 (K)	Monitoring output (RT line 2), max. 50 mA	
X6.5	DO 3.2 (A)	Alarm output (RT line 2), max. 50 mA	RT line 2
X6.4	DO 3.3 (S)	Fault output (RT line 2), max. 50 mA	
X6.3	-	Reference potential (do not connect to P-)	
X6.2	DO 4.2	Placeholder for FAS resistor	
X6.1	DO 4.3	Placeholder for FAS resistor	

No.	Name	Description (as digital inputs/outputs)
X1.1	DO 2.3	When not in use: placeholder for FAS resistor
X1.2	DO 2.2	When not in use: placeholder for FAS resistor
X1.3	-	Reference potential (do not connect to P-)
X1.4	DO 1.3 (S)	Freely configurable digital output 1.3, max. 50 mA
X1.5	DO 1.2 (A)	Freely configurable digital output 1.2, max. 50 mA
X2.1	DO 1.1 (K)	Freely configurable digital output 1.1, max. 50 mA
X2.2	DI 1.1 (Z)	Freely configurable digital input 1.1, 0 to 28 V, active minus or plus
X2.3	-	Reference potential (do not connect to P-)
X2.4	LINIE 1 (T)	No function
X2.5	FE	Functional earth
X3.1	DO 2.1	Freely configurable digital output 2.1, max. 50 mA
X3.2	DI 2.1	Freely configurable digital input 2.1, 0 to 28 V, active minus or plus
X3.3	-	Reference potential (do not connect to P-)
X3.4	LINIE 2 (R)	No function
X3.5	FE	Functional earth
X4.5	FE	Functional earth
X4.4	LINIE 3 (R)	No function
X4.3	-	Reference potential (do not connect to P-)
X4.2	DI 3.1	Freely configurable digital input 3.1, 0 to 28 V, active minus or plus
X4.1	DO 3.1	Freely configurable digital output 3.1, max. 50 mA
X5.5	FE	Functional earth
X5.4	LINIE 4 (T)	No function
X5.3	-	Reference potential (do not connect to P-)
X5.2	DI 4.1 (Z)	Freely configurable digital input 4.1, 0 to 28 V, active minus or plus
X5.1	DO 4.1 (K)	Freely configurable digital output 4.1, max. 50 mA
X6.5	DO 3.2 (A)	Freely configurable digital output 3.2, max. 50 mA
X6.4	DO 3.3 (S)	Freely configurable digital output 3.3, max. 50 mA
X6.3	-	Reference potential (do not connect to P-)
X6.2	DO 4.2	When not in use: placeholder for FAS resistor
X6.1	DO 4.3	When not in use: placeholder for FAS resistor

# Connection – TMA (2 lines)

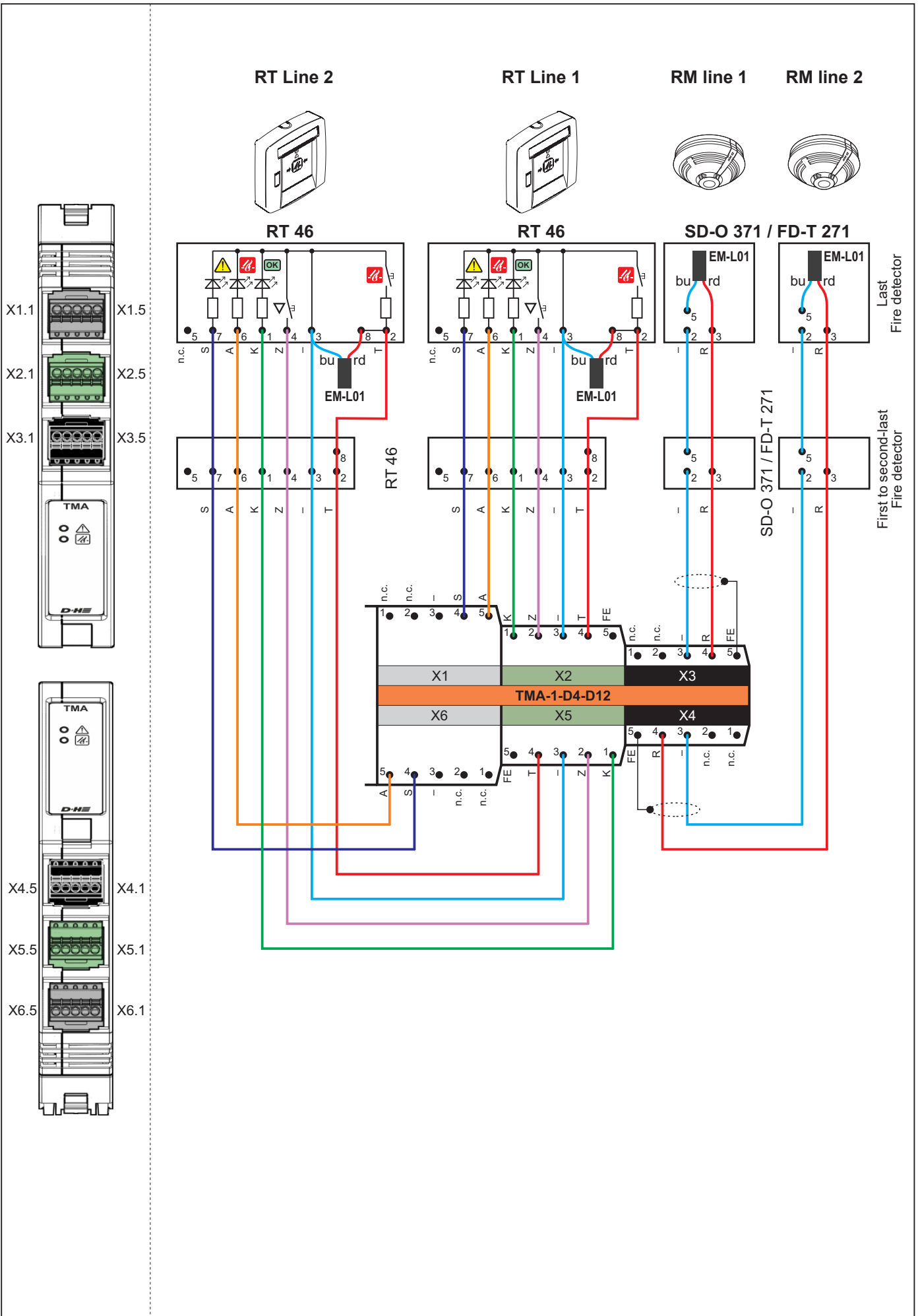

## Connection – TMA parallel connection RT

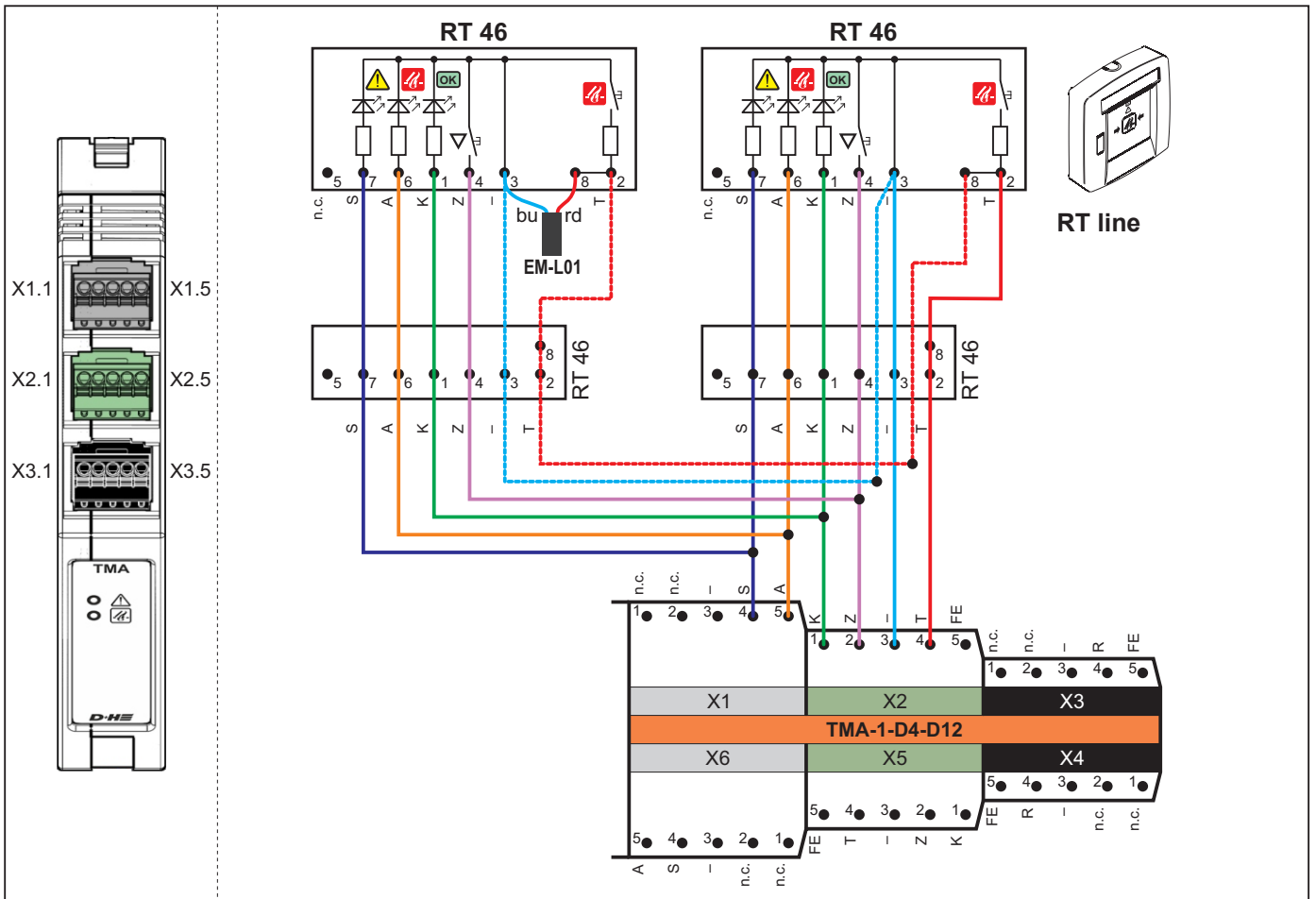

## Connection – TMA to fire alarm system (FAS)

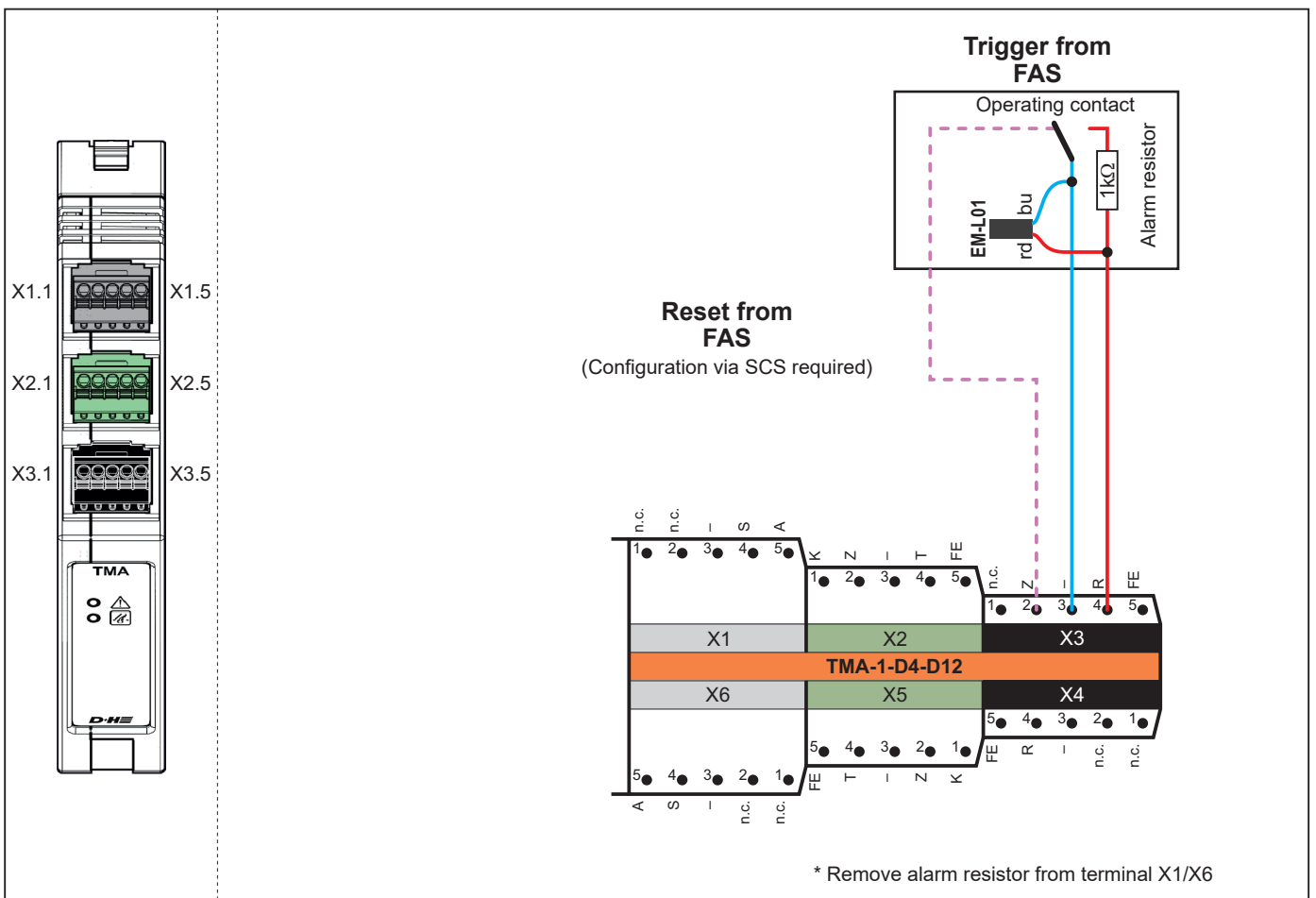

## Connection – TMD-1-ACR



## Connection – Ringbus TMD-1-ACR

No.	Name	Description
X4.5	FE	Functional earth
X4.4	PORT A: ACR.B	ACR-Interface Port A
X4.3	PORT A: ACR.A	ACR-Interface Port A
X4.2	PORT A: ACR-	ACR-Interface Port A
X4.1	PORT A: ACR+	ACR-Interface Port A
X5.5	FE	Functional earth
X5.4	PORT B: ACR.B	ACR-Interface Port B
X5.3	PORT B: ACR.A	ACR-Interface Port B
X5.2	PORT B: ACR-	ACR-Interface Port B
X5.1	PORT B: ACR+	ACR-Interface Port B

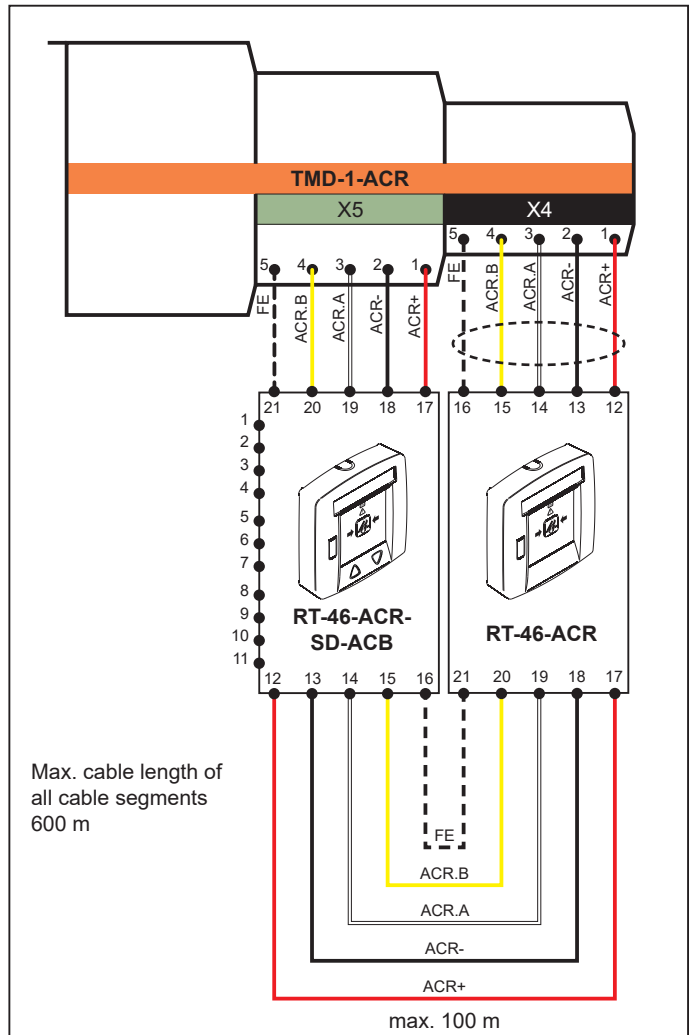

## Connection – Ringbus RT 46-ACR (-SD-ACB)

No.	Connection	Name	Description	
12	X4	PORT A: ACR+	Supply lines	
13	X4	PORT A: ACR-		
14	X4	PORT A: ACR.A		Communication lines
15	X4	PORT A: ACR.B		
16	X4	FE	Functional earth	
17	X5	PORT B: ACR+	Supply lines	
18	X5	PORT B: ACR-		
19	X5	PORT B: ACR.A	Communication lines	
20	X5	PORT B: ACR.B		
21	X5	FE		Functional earth

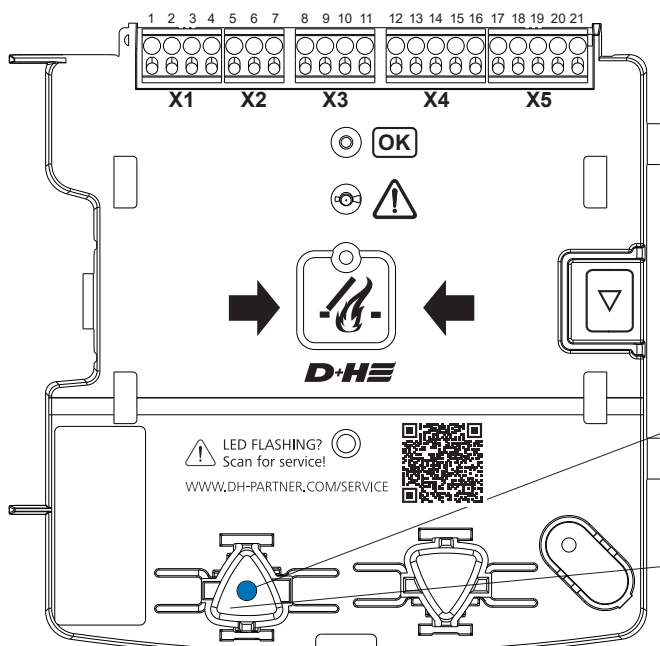

### Please Note:

Cabling of the system using standard cable J-Y(St)Y 2x2x0.8

### DO2

Free configurable display (adjustable via SCS)

### LT2

Integrated ventilation button (parameterisable via SCS)

## Connection – Periphery RT 46-ACR-SD-ACB

No.	Connection	Name	Description
1	X1	DO1	Freely configurable digital output 1, max. 10 mA; adjustable via SCS
2	X1	-	Reference potential
3	X1	DI1 / LT1-AUF	Freely configurable digital input 1 / OPEN LT 1; adjustable via SCS
4	X1	DI1 / LT1-AUF	Freely configurable digital input 2 / CLOSE LT 1; adjustable via SCS
5	X2	R	RM line, max. 30 mA
6	X2	-	Reference potential
7	X2	FE	Functional earth
8	X3	ACB.A	Communication lines of the ACB-interface / to be kept free for future applications
9	X3	ACB.B	
10	X3	ACB+	Supply input of the ACB-interface; galvanically isolated / to be kept free for future applications
11	X3	ACB-	Reference potential of the ACB-interface; galvanically isolated / to be kept free for future applications

### Connection – Digital inputs and outputs

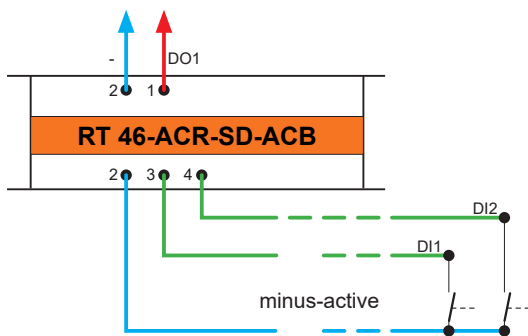

### Connection – External ventilation buttons

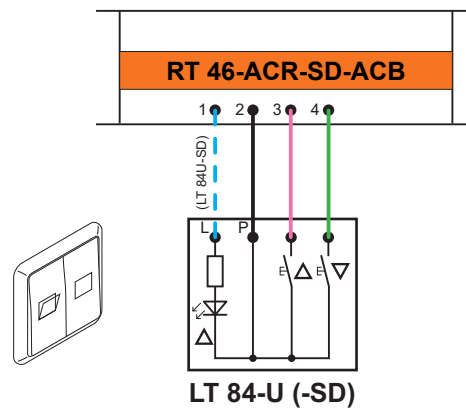

### Connection – RM line (analogue monitoring)

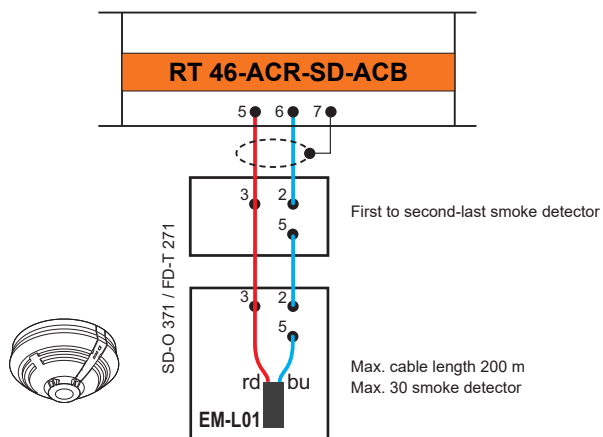

### Connection – Addressable RM line (digital monitoring)

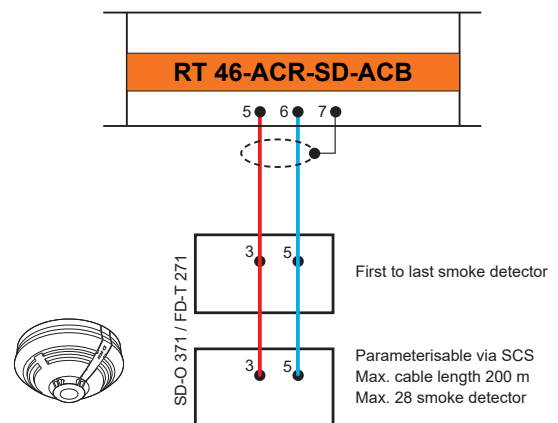

## Description of the inputs and outputs

Designation	Description
-	<b>Reference potential / negative:</b> used as the reference potential for external peripherals (e.g. SHEV operation panel or LT). May not be connected to P-. The reference potentials of more than one power supply module may not be connected together.
ACB.A x / ACB.B x MOT.a x / MOT.b x	<b>Group (ACB):</b> used for the connection of bus-capable drives. ACB.A x and ACB.B x are necessary for communication with the drives. MOT.a x and MOT.b x are necessary for supplying the connected drives. The maximum output current of the supply is 10 A. The supply is permanently short-circuit resistant and the fuse used is self-resetting.
ACN D+ / ACN D- Shield	<b>AdComNet connection:</b> used for interconnecting more than one CPS-M1 and for interconnecting with ACN-CM501, ACN-IO501, ACN-BI501-USB and ACN-GW501-MRTU. If this connection is not used, it must nevertheless be terminated with a resistor (110 Ohm).
BATT+ / BATT-	<b>Battery connection:</b> may only be used for connecting the secondary power supply (battery).
COM x / NC x / NO x (monostable, CRM)	<b>Isolated output:</b> used for the triggering of external systems. The maximum contact current is 1 A. The minimum contact current to ensure permanent safe operation is 10 mA. The maximum contact voltage is 35 V DC. The contact is not suitable for switching 230 V AC. The output can be supplied with emergency power. This is to be taken into consideration in the battery capacity calculation.
COM x / NC x / NO x (bistable, BRM)	<b>Isolated output:</b> used for the triggering of external systems. The maximum contact current is 3 A. The minimum contact load to ensure permanent safe operation is 5 V / 10 mA. The maximum contact voltage is 30 V DC or 265 V AC.
DI x.x	<b>Digital input:</b> used for the evaluation of switch signals. The input voltage range is 0 V DC to 28 V DC. The pull-up resistor for the evaluation of an active negative signal is integrated. The pull-down resistor for the detection of an active positive signal is integrated. The switching contact is briefly (< 100 ms) loaded with 16 mA. The input DI 1.1 of the controller module cannot currently be used.
DO x.x	<b>Digital output:</b> used for the triggering of displays or relays. The output voltage range of an activated output is 17 V DC to 25 V DC. The output voltage range applies for a maximum output current of 50 mA. The connection is permanently short-circuit resistant and the fuse used is self-resetting. If the output is deactivated, the output is open / has a high resistance. Active negative inputs cannot be switched using the output. The output can be supplied with emergency power. This is to be taken into consideration in the battery capacity calculation.
FE	<b>Functional earth:</b> can be used as the cable shielding connection when connecting a smoke detector line. May only be used as a cable shielding connection.
LINE / RT x	<b>Line connection:</b> used for connecting a smoke detector line or an SHEV operation panel line. Furthermore, external systems (e.g. fire detectors) can be connected.
LINE / RM x	A maximum of 30 smoke detectors or 10 SHEV operation panels can be connected. The connection is permanently short-circuit resistant and the fuse used is self-resetting. Cable monitoring is performed via the EM-L01.
MOT.A x / MOT.B x E/HS	<b>Group (polarity change):</b> used for the connection of conventional pole-changing drives. MOT.A x and MOT.B x are necessary for the supply and for controlling the direction. The maximum output current of the supply is 10 A. The supply is permanently short-circuit resistant and the fuse used is self-resetting. E/HS is used for cable monitoring and for triggering the high-speed function.
n.c.	The terminal is not connected.
N+	<b>Operating voltage not supplied with emergency power:</b> used for the supply of external peripherals. The output voltage range is 22 V DC to 24 V DC. The maximum output current is 440 mA.
P-	<b>Group reference potential / group negative:</b> used as the reference potential for external drives. May not be connected to -. The group reference potentials of more than one power supply module may not be connected together.
+	<b>Operating voltage supplied with emergency power:</b> used for the supply of external peripherals. The current consumption of the connected peripherals must be taken into consideration in the battery capacity calculation. The output voltage range is 19 V DC to 27 V DC. The maximum output current is 440 mA.
SGI x	This function has not yet been implemented.
SNT+ / SNT-	<b>Mains power connection:</b> may only be used for connecting the primary power supply (power pack).
TCSU1	<b>Temperature sensor connection:</b> may only be used for connecting the TCSU1-RJ12. The maximum cable length to ensure permanent safe operation is 2 m.
TP-C1	<b>Touch panel connection:</b> may only be used for connecting the TP-C1-35-RJ12.

## 230 V AC Emergency power supply – NSV 401

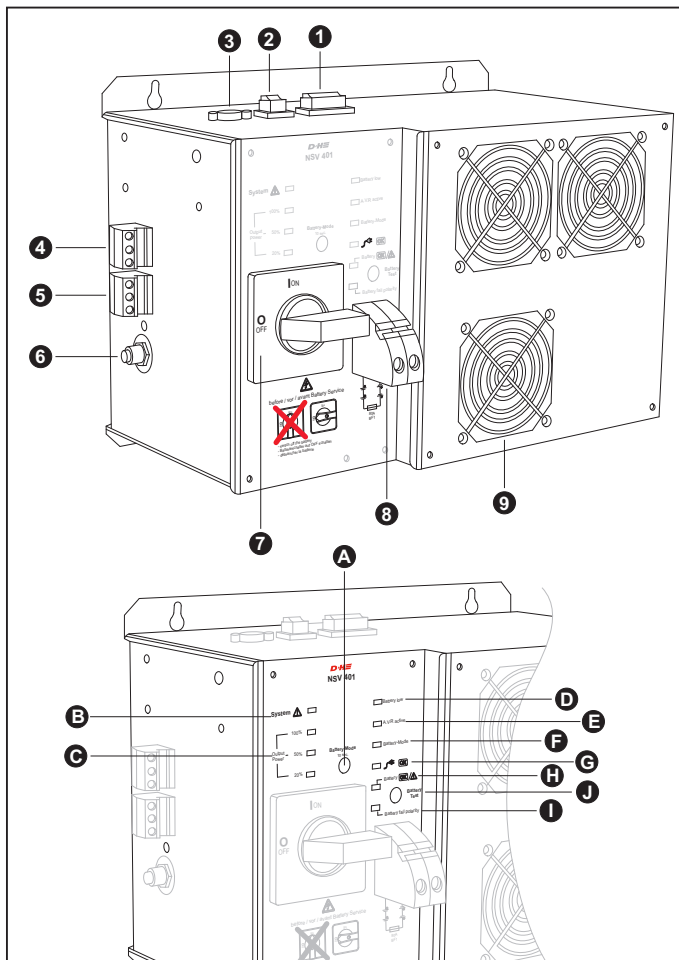

### Functions:

- The NSV 401 is an emergency power supply for 230 V AC D+H SHEV systems. In combination with the AM 230, the NSV 401 supplies the connected SHEV drives with mains voltage. In case of power failure they are supplied with 230 V AC for 7 minutes (When the retriggering function is switched on after approx. 30 minutes) by the system's battery bank (72 hr. standby).
- Any ventilation units connected to the system may not be supplied by the NSV 401.
- True sinusoidal voltage at the output of the NSV 401
- Marginal distortion factor
- The parallel circuit of several NSV 401 is prohibited
- 72 hr. standby without power supply

No.	Name
1	Connection for collective fault
2	External ON/OFF control unit
3	PC service interface
4	230 V AC - IN (mains supply)
5	230 V AC - OUT (back-up operation)
6	Resettable fuse
7	Disconnect switch for batteries
8	Connection of the batteries (observe correct polarity)
9	Internal fans

No.	Name	Action	Description		
A	Battery-Mode	is pushed	System is operated for 10 sec. in back-up operation		
B	System	lights up	A malfunction of NSV has occurred or the NSV 401 output displays a short circuit		
		lights up with Output Power	The NSV 401 is overloaded		
C	Output Power	lights up	The display bar indicates the load at the NSV 401 output		
		does not light up	No load present at the output		
D	Battery low	lights up in mains operation	NSV 401 charges the battery bank, the LED turns off when an adequate charge level has been reached		
		lights up in back-up operation	Remaining battery charge has dropped below a defined critical level		
E	A.V.R. active (Automatic Voltage Regulator)	lights up	Undervoltage or overvoltage is detected on the supply network. The NSV 401 reduces / increases the output voltage by approximately 13% in order to protect the devices		
F	Battery-Mode	lights up	The NSV 401 runs in back-up operation (AC power supply not present or beyond the tolerance range). If necessary, the required power will be obtained from the battery bank		
G	Mains OK	lights up	The NSV 401 runs in mains operation		
		does not light up	Mains voltage beyond the tolerance range, no mains voltage is present at the input (defective fuse or power failure)		
		flashes	Mains voltage is present, but no request from the actuator module		
H	Battery	lights up green	Battery bank OK		
		lights up red	Battery bank not connected or too high/low impedance of the battery circuit		
		flashes red	System in back-up operation		
		flashes green / red	Battery test		
I	Battery fail polarity	lights up (signal sounds)	The battery bank has not been connected with correct polarity, change the polarity		
J	Battery Test	The button (J) must be pressed and held for 3s to initiate the test.			
		The battery LED (H) indicates the test mode (quickly changes between red and green). Duration of test approximately 15s --> After the manual test start, internal resistance is measured and the result is indicated by the battery LED (H):			
		lights up red = $R_i < 10 \text{ mW}$ or $R_i > 210 \text{ mW}$			
		flashes green = $10 \text{ mW} < R_i < 210 \text{ mW}$			
		(The number of flashes indicate the RI value)			
			Ri Value [mW]	Number of flashes	Ri in %
			10...30	10	100
			31...50	9	90
			51...70	8	80
			71...90	7	70
	91...110	6	60		
	111...130	5	50		
	131...150	4	40		
	151...170	3	30		
	171...190	2	20		
	191...210	1	10		

## Safety Notes

Operating voltage 230 VAC!

Risk of injury from electric shock!

- Only an authorised electrician may connect and work on the NSV 401
- The NSV 401 may not, under any circumstances, be operated without an earthed conductor!
- The mains connection must be in-phase. The battery's negative conductor is connected with the N conductor of the primary energy source (public grid). Phase detection in the unit ensures that the L phase of the primary energy source is not connected to the battery's negative pole in the event of improper connection. If the unit is not properly connected, it is not ready for use.
- Observe the maximum output limits!
- Do not install the NSV 401 near heat sources; unrestricted air circulation must always be ensured
- Only use in dry spaces
- In case of surface condensation, at least 2 hours are required for acclimatisation
- Only intended for installation indoors
- Only use unaltered D+H original parts

## Technical Data

Type	NSV 401
<b>Mains input:</b>	
Input range	230 V AC, -10% / +15%
Nominal frequency	50 Hz
Overvoltage control	ja (-13%)
Undervoltage control	ja (+13%)
Nominal power	max. 3200 VA / 2000 W (14,6 A)
<b>NSV output:</b>	
Max. connection load 18 Ah Batteries	3200 VA / 2000 W
Max. connection load 12 Ah Batteries	1600 VA / 1000 W
Mains operation	197 - 250 V AC
Back-up operation	230 V AC (Sinus +/- 5%)
Max. output current	13,9 A
Overload capacity	[110 ... 130 %]: 10-25s, > 130% 1,5s
Efficiency	AC -> AC > 95%
<b>General:</b>	
Permissible temperature range	-5 ... +40°C
Recommended temperature	+15 ... +25°C
Cooling	Fan cooling
Noise level	< 45 dB
Dimensions (W x H x D)	355 x 250 x 205 mm
<b>Batteries:</b>	
Nominal voltage of battery connection	48 V DC (nominal)
max. battery dimensions (W x H x D)	181 x 167 x 76 mm (=Typ 5)
Battery capacity 18 Ah	4 x Art.-Nr. 70.200.05 Typ 5 (Same as "Long WP18-12")
Battery capacity 12 Ah	4 x Art.-Nr. 70.200.00 Typ 4 (Same as "Long WP12-12")

## Schematic design – NSV 401

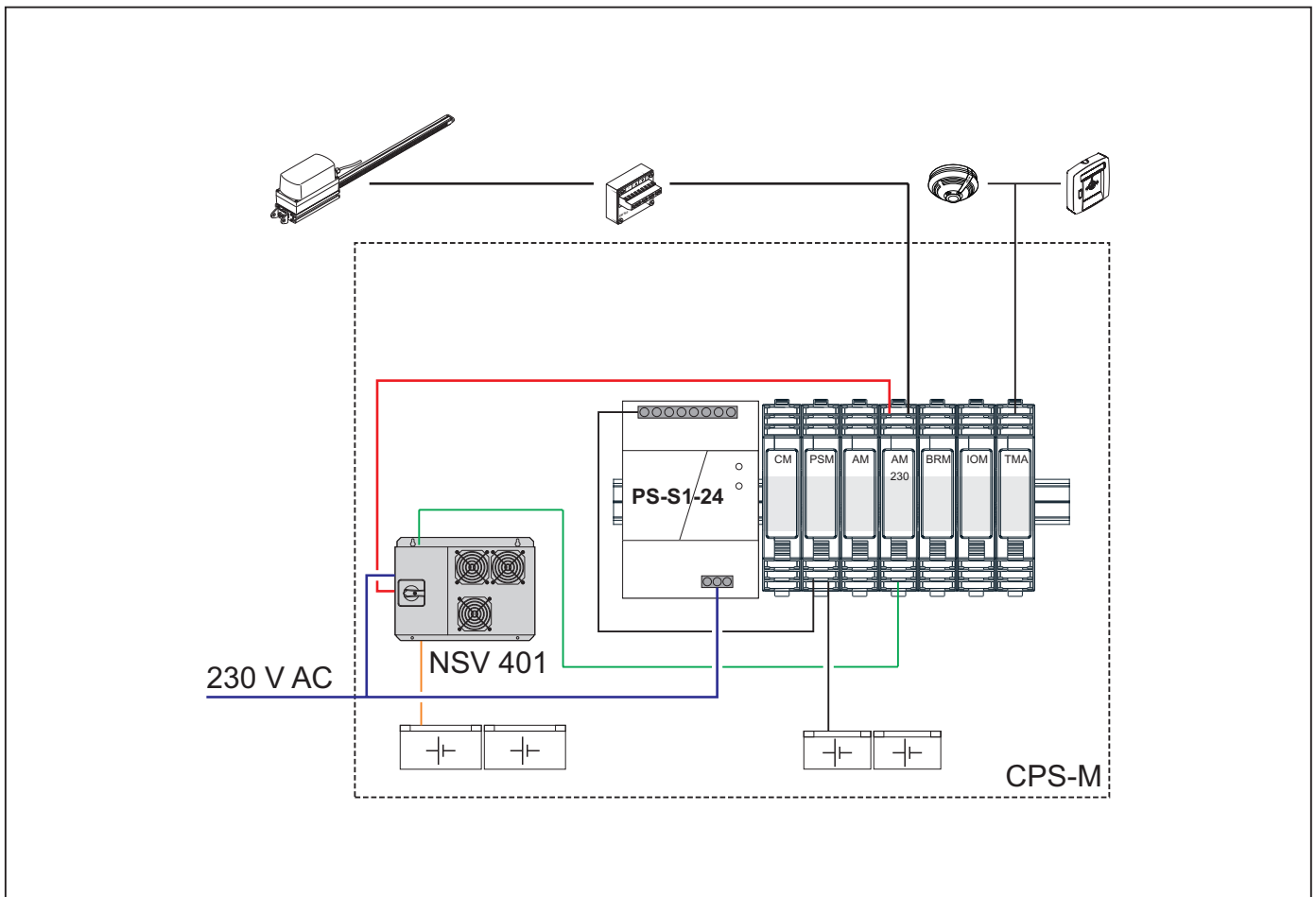

# Connection overview – NSV 401

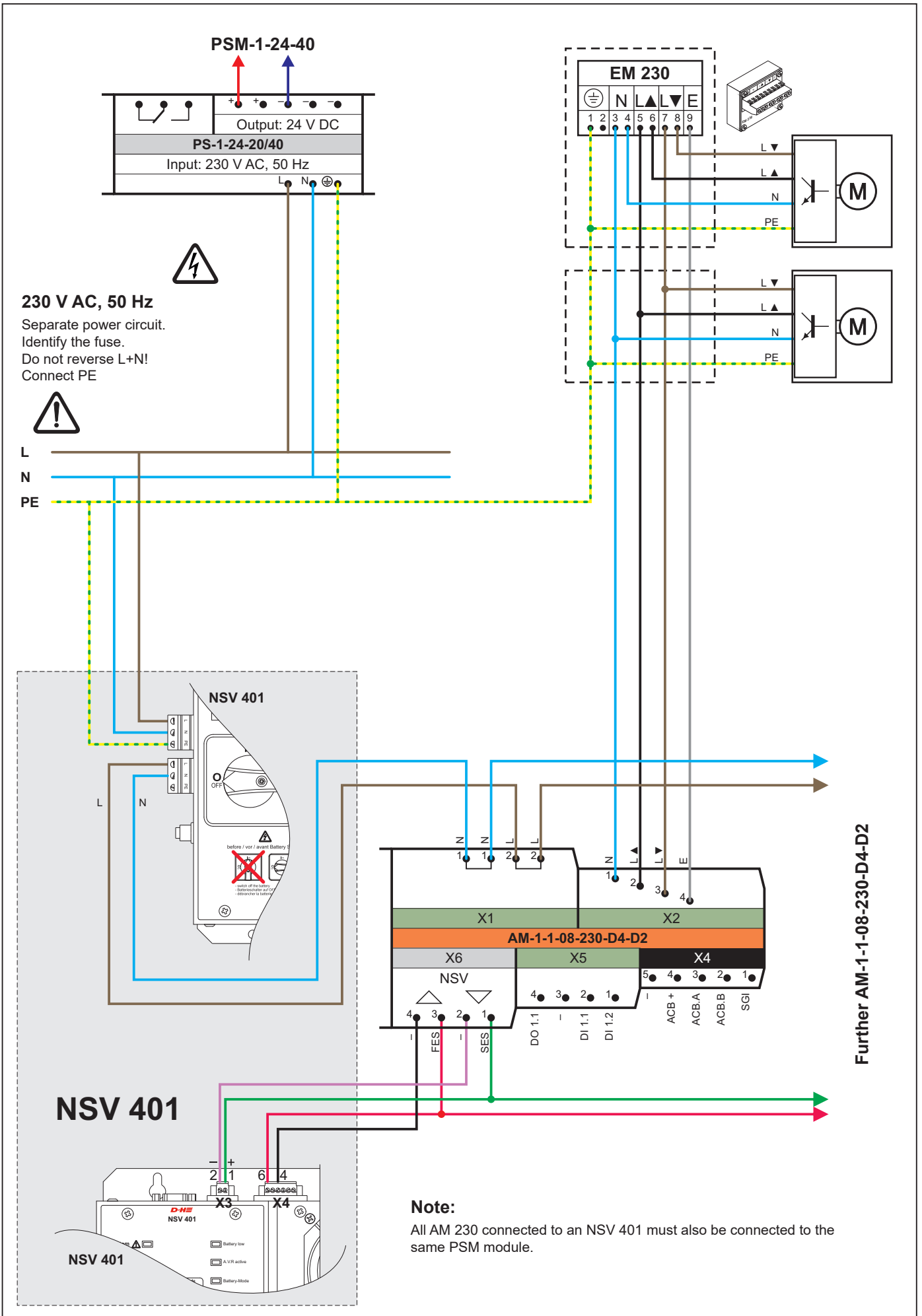

## Connecting / changing batteries

Batteries are capable of quickly discharging large amounts of energy in the event of a short circuit. Exercise special caution when working to prevent damages. Wrist watches, rings and other metal objects must be removed before working on the batteries. Only use insulated tools.

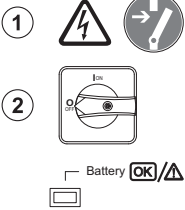
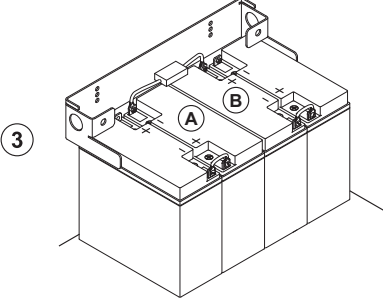
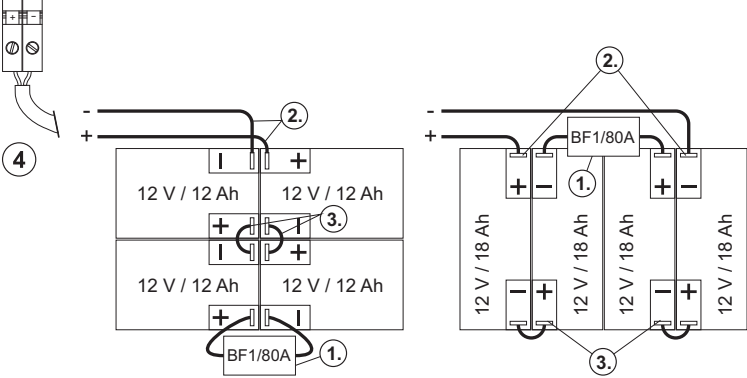
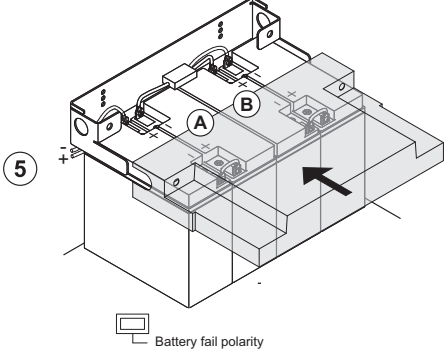
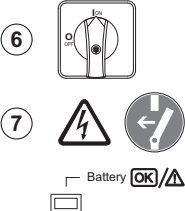
	<ol style="list-style-type: none"> <li>1. Disconnect NSV resp. control panel from mains. (Mains fuse or separate switch for NSV supply.) <b>WARNING! The output of the NSV 401 is not deenergised!</b></li> <li>2. Set battery circuit breaker to the OFF position. <b>WARNING! Resistance when turning the circuit breaker.</b> Battery monitor turns red</li> </ol>
	<ol style="list-style-type: none"> <li>3. Position the batteries in the intended area and connect as indicated in the connection diagram; install the enclosed fuse (BF1/80A) between battery (A) and battery (B). <b>WARNING! A short circuit may occur if the cover is removed!</b></li> </ol>
	<ol style="list-style-type: none"> <li>4. Observe the correct connection order (1.) ... (2.) ... (3.)! <b>WARNING! Make sure the polarity is correct!</b></li> </ol>
	<ol style="list-style-type: none"> <li>5. The cover must be in place to eliminate the risk of short circuits and electrical shocks!  If the LED blinks and an alarm has sounded, the battery has been connected with incorrect polarity, change the battery polarity.  <b>WARNING! If the polarity is incorrect and the battery's main switch is on, the inverter will be destroyed!</b></li> </ol>
	<ol style="list-style-type: none"> <li>6. Set the circuit breaker back to ON. <b>AWARNING! If the polarity is incorrect and the battery's main switch is on, the inverter will be destroyed!</b></li> <li>7. Switch the power on again. (Mains fuse or separate switch for NSV supply.) The battery monitor must light up green</li> </ol>

# Commissioning and configuration with the SCS software

The D+H Service and Configuration Suite (SCS) is used for commissioning and programming.

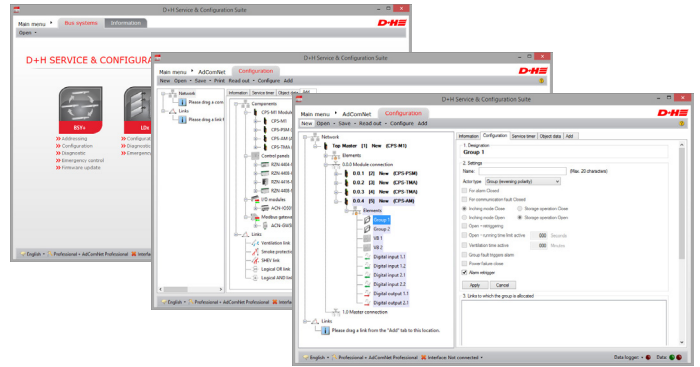

## Functions programmable via SCS:

### CM :

1. Designation  
**Digital input 1.2**

2. Settings  
Designation: \_\_\_\_\_ (max. 20 characters)

Functionality selection: **Not allocated**

Timer function selection:  
 Alarm  
 Alarm pulse  
 Alarm reset (with RT Close pulse)  
 Alarm reset with RT Close  
 Inverted  
 Alarm reset with stop  
 Alarm and Alarm reset (with RT Close pulse)  
 Malfunction

3. Links to which the digital input is allocated  
SHEV link 1

1. Designation  
**Isolated output 1**

2. Settings  
Designation: \_\_\_\_\_ (max. 20 characters)

Functionality selection: **Not allocated**

Timer function selection:  
 Alarm  
 Alarm pulse  
 Alarm reset pulse  
 Malfunction  
 Not direction CLOSE signal

3. Links to which the digital output is allocated  
SHEV link 1

### Standard configurations Controller Module (CM)

The isolated outputs from Controller Module are pre-configured by all standard control panels. The terminal X1 is for general fault and the terminal X2 for general alarm signals. The digital inputs X6.2 and X6.3 are pre-configured for general open- and general close- signals.

### AM 24 :

1. Designation  
**Group 1**

2. Settings  
Name: \_\_\_\_\_ (Max. 20 characters)

Actor type: **Group (reversing polarity)**

Short-circuit  
 Close on Magnet  
 Window-lock unit  
 Alarm devices  
 Inching  
 Inching mode Open  
 Open - retrigging  
 Open - running time limit active  
 Ventilation time active  
 Group fault triggers alarm  
 Close on mains outage  
 Alarm re-clocking

Switching time: 0,5 seconds

3. Links to which the digital output is allocated  
SHEV link 1

### AM 230 :

1. Designation  
**Group 230V 1**

2. Settings  
Designation: \_\_\_\_\_ (max. 20 characters)

Actuator type: **Group (phase activation)**

Close on alarm  
 Close on ACN communication fault  
 Inching mode Close  
 Inching mode Open  
 Open - retrigging  
 Open - running time limit active  
 Ventilation time active  
 Group fault triggers alarm  
 Close on mains outage  
 Alarm re-clocking  
 Alarm with HS

Switching time: 0,5 seconds

Open delay  
 Close delay  
 Alarm delay

Cable monitoring  
 De-energising: 7 Minutes

Apply Cancel

### TMA :

1. Designation  
**Line 1**

2. Settings  
Designation: \_\_\_\_\_ (max. 20 characters)

RM can only be locally reset  
 Line fault triggers alarm  
 Two-detector dependency  
 Reset in case of pending alarm on the RM line  
 RT-Closed input generating pulse

Alarm delay: 0 h 0 min 0 s

Linetype: Standard

Apply Cancel

### Alarm with HS

**ATTENTION!** This function must only be used in conjunction with corresponding D+H high speed drives. If D+H drives without high speed or third-party drives are connected, activation can destroy the drive!

## Description of the software functions

Designation	Connection	Description
Digital output	Output inverted	The output issues the status of the link inverted.
	Functionality selection	SHEV link: Alarm / Alarm Reset / Alarm Pulse / Fault / Not Closed Ventilation link: Not Closed / LT Open forwarding / LT Closed forwarding
	Supplied with emergency power	The output is also triggered in the event of a mains outage. An additional 0.072 Ah is to be taken into consideration in the battery capacity calculation. Furthermore, the current consumption of the connected peripherals is to be taken into consideration.
	Functionality	SHEV link: Alarm / Alarm Pulse / Alarm Reset and RT Closed / Alarm and Alarm Reset with RT Closed / Fault Ventilation link: LT Open / LT Closed / LT Stop / LT Open pulse / LT Closed pulse / LT Open and Closed pulse / LT Closed and Open pulse / LT Open pulse and Closed pulse
Digital input	Inverted	The status of the input is forwarded to the link inverted.
	Active negative	The input is activated if switched to -.
	Active positive	The input is activated if switched to P+ or N+.
Group	Actuator type	The group is used for triggering ACB drives or pole-changing drives. The type used must be selected for each group.
	Alarm re-clocking	The group will be triggered every 2 minutes for 30 minutes in the event of an alarm. This function is a requirement of VdS 2581.
	Open – running time limit	The group moves in the OPEN direction for the set time if the ventilation button is switched to the OPEN direction.
	Open – retriggering	The group once more moves in the OPEN direction for the set time if the ventilation button is again switched to the OPEN direction.
	For alarm Closed	The group moves in the CLOSED direction if the SHEV link to which the group is assigned is triggered.
	For communication fault Closed	The group moves in the CLOSED direction if a communication fault occurs within a link to which the group is assigned.
	Group fault triggers alarm	In the event of a group fault (e.g. a monitoring cable is interrupted or an addressed ACB drive is not available), the SHEV link to which the group is assigned is triggered.
	Ventilation time active	The group automatically moves in the CLOSED direction upon expiry of the set ventilation time.
	Mains outage CLOSED	The group automatically moves in the CLOSED direction in the event of a mains outage. Only the control panel groups move in the CLOSED direction in the event of a mains outage. Groups in the same link belonging to another CPS-M are not affected by this.
	Storage operation OPEN	The group moves in the OPEN direction when a ventilation button of the ventilation link is pressed once.
	Storage operation CLOSED	The group moves in the CLOSED direction when a ventilation button of the ventilation link is pressed once.
	Stop-hold function	The supply cables MOT.A x and MOT.B x are short-circuited in the Stop status. A short circuit between these two cables can no longer be recognized as being a fault in this status.
	Button operation OPEN	The group moves in the OPEN direction for as long as the ventilation button of the ventilation link is pressed.
	Button operation CLOSED	The group moves in the CLOSED direction for as long as a ventilation button of the ventilation link is pressed.
Line	Line fault triggers alarm	In the event of a line fault (e.g. an interrupted cable), the SHEV link to which the line is assigned is triggered.
	Smoke detector can only be locally reset	A smoke detector alarm cannot be reset by pressing the "SHEV CLOSED" button on the SHEV button panel. It is possible to reset the alarm via the touch panel.
	Two-detector dependency	(Only with SD-O 371/FO 1362) Alarm will be triggered only, if at least two smoke detectors of one line respond. False alarm of one smoke detector will be prevented. Two smoke detectors in one room must be always installed. If only one smoke detector is connected to one line, switch must be on OFF!
Isolated output	Output inverted	The output issues the status of the link inverted.
	Functionality selection	SHEV link: Alarm / Alarm Reset / Alarm Pulse / Fault / Not Closed Ventilation link: Not Closed / LT Open forwarding / LT Closed forwarding
	Supplied with emergency power (monostable, CM)	The output is also triggered in the event of a mains outage. This must be taken into consideration in the battery capacity calculation.
	Failsafe in case of power failure (bistable, BRM)	With this the state of the potential-free contact can be defined, which is to be taken in case of a failure of the mains and battery supply. If the "None" configuration is selected, the last status is retained.
Event log	internal	All status changes of the CPS-M are written with time stamp in an event log. These can be read out via the SCS software.

## Operation – Touch panel (optional)



### Start screen

- Displays the overall status of the control panel



### Settings

- Setting the display language

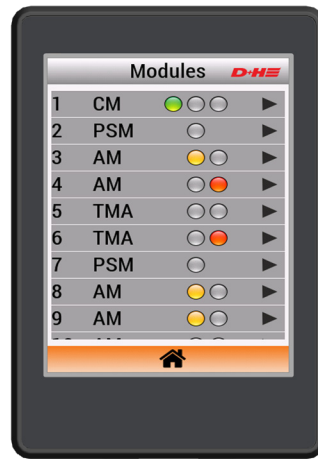

### Modules

- Overview of all modules used
- Display of the respective statuses similar to the LEDs on the respective module



### CM - Control module

- Display of the module status
- Display of the status of the inputs and outputs

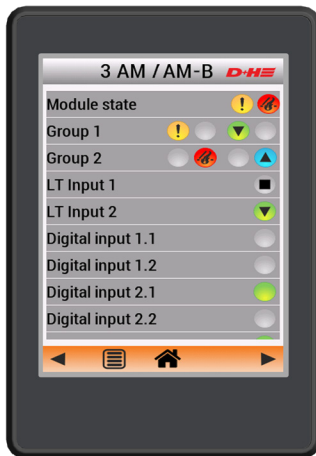

### AM 24 - Actuator module

- Display of the module status
- Status display of the groups
- Status display of the inputs and outputs

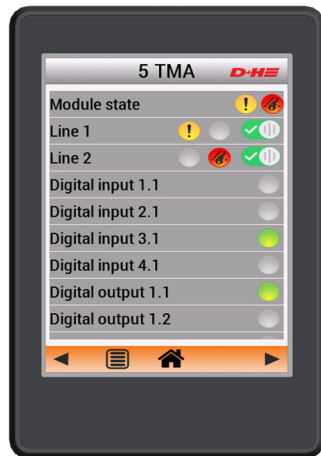

### TMA - Trigger module

- Display of the module status
- Status display of the lines
- Switch on and off, and resetting the lines
- Status display of the inputs and outputs

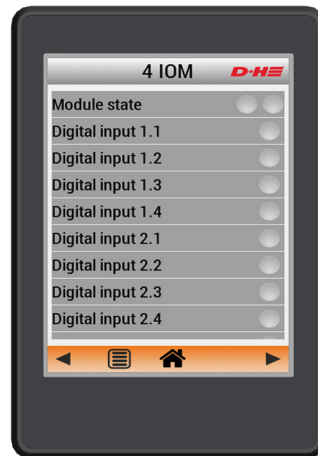

### IOM - I/O module

- Display of the module status
- Display of the status of the inputs and outputs

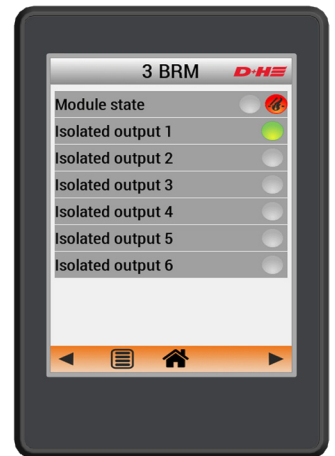

### BRM - Relay module

- Display of the module status
- Display of the status of the inputs and outputs

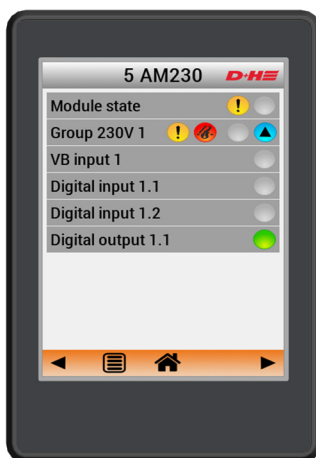

### AM 230 - Actuator module

- Display of the module status
- Status display of the group
- Status display of the inputs and outputs

## Operation – Daily ventilation

Ventilation button or SHEV button with RT 46-LT ventilation function required.

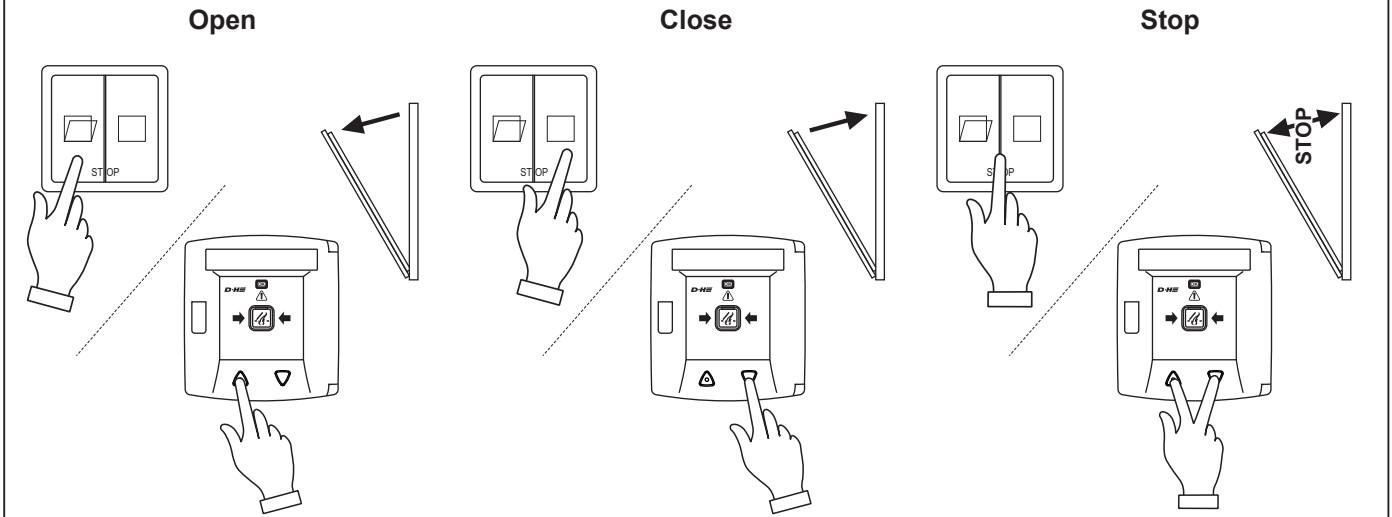

## Operation – Weather automation

**With connected wind or rain detector.**

When the corresponding sensor is triggered, the control panel group is closed. In case of an SHEV alarm, the system also starts in wind or rain.

**Do not ventilate using the smoke vent button, as otherwise there is a risk of wind or water damage.**

If gap ventilation is desired in bad weather, the weather automation can be switched off using an **optional automatic switch**.

If **no automatic switch** is present, **gap ventilation is not possible in poor weather**. If the weather automation is switched on, the system closes in case of wind or rain.

It does **not** open again automatically after the wind or rain stops. Opening the system for ventilation using the ventilation button.

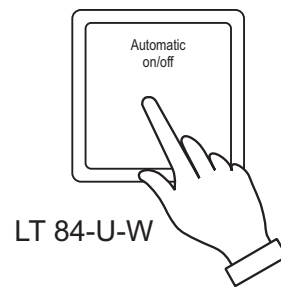

## Operation – SHEV



**Safety system, protects human life and real property value!**  
**Function check once a year by a specialist company authorised by the manufacturer.**

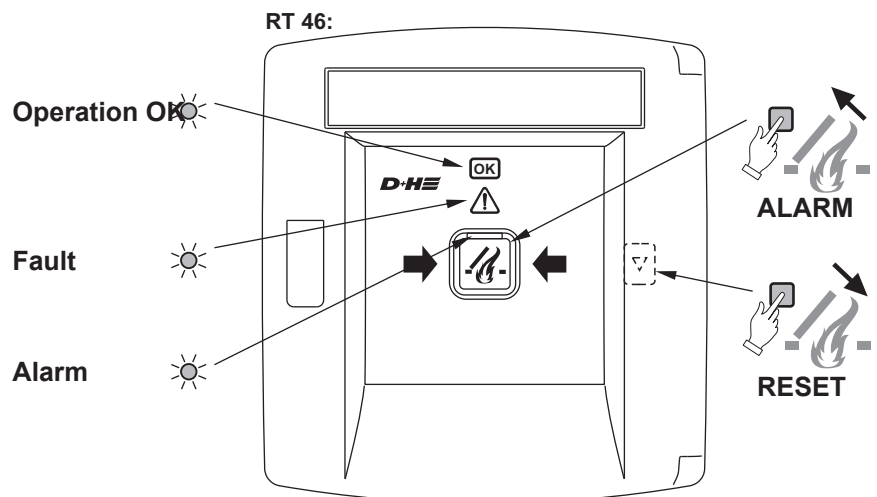

## Operation – Trigger on alarm

### Manual opening with smoke vent button

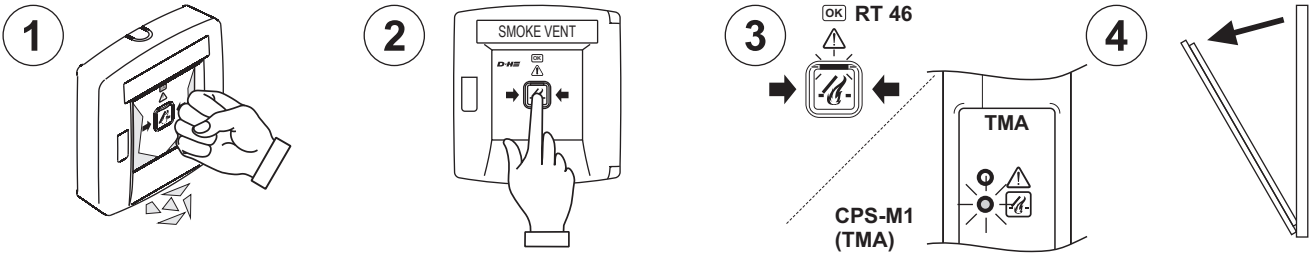

### Automatic opening with fire detector

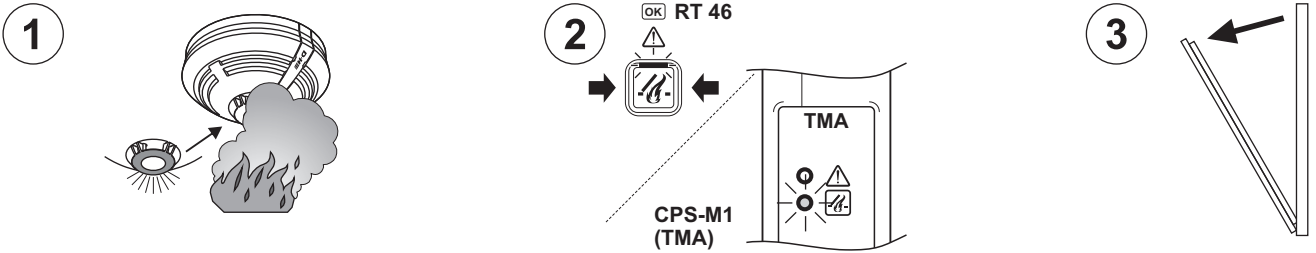

### Automatic opening through external control (e.g. central fire alarm)

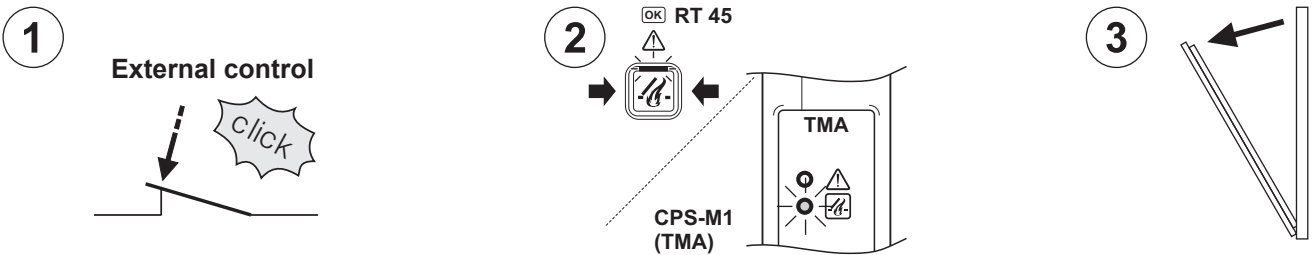

## Operation – Closing after alarm

### For manual triggering using smoke vent button

Opening the housing (control panel and button) using the accompanying key.

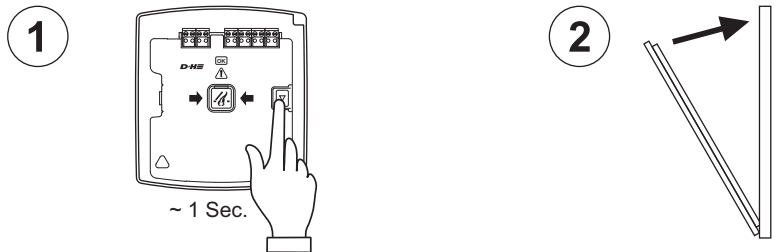

### When triggered by a fire detector or external control

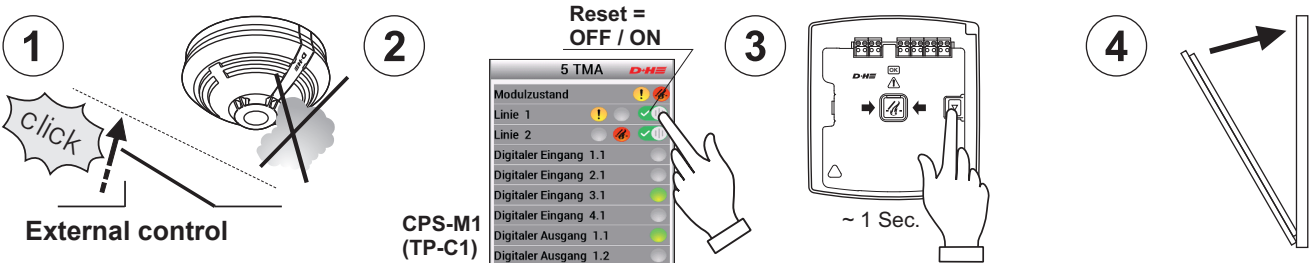

### Emergency closing when alarm cannot be reset

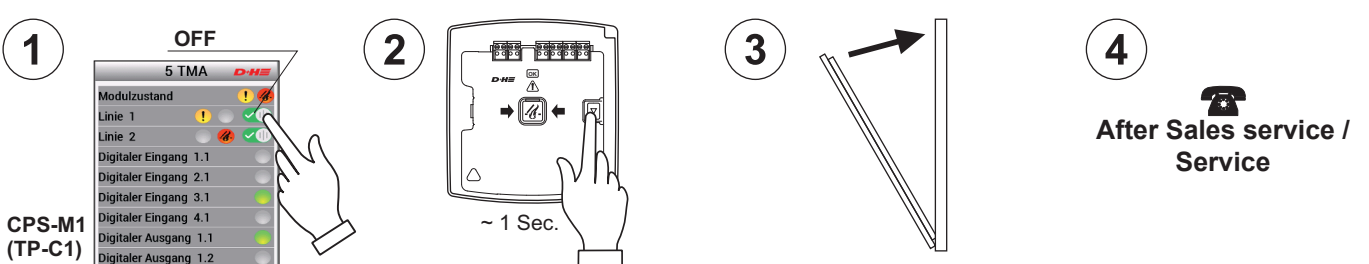





## Inspection

Regular visual inspection between maintenance by the operator or a trained person.  
Immediately correct any defects.

Displays:

- Green LEDs in the buttons must illuminate.
- Yellow LEDs in the buttons and the control panel are not allowed to illuminate or flash (fault).
- If the green LEDs do not illuminate or if the yellow LEDs illuminate or flash, contact After Sales service.

Visual inspection:

- Check all devices and cable connections for external damage and dirt.
- The function of fire detectors, smoke vent buttons, smoke extraction systems etc. must not be impaired by stored articles or structural changes.

## Maintenance and cleaning

Carried out once a year by a specialist company authorised by the device manufacturer.

Carry out cleaning and maintenance work only when the system is de-energised.

Replace the inspection plate, maintain the operational book.

The inspection and maintenance must take place in accordance with the D+H maintenance instructions.

The respective current D+H maintenance instructions are authoritative.

An authorised D+H specialist company receives this automatically and has been given special training by D+H in carrying out this maintenance.

The following tests must be carried out during maintenance:

- External expert assessment / inspection of the system components
- Checking all relevant voltage supply units
- Function test of the connected system components
- Logging the proper completion of maintenance and
- Labelling in accordance with requirements

Only original D+H spare parts may be used. Repairs are carried out by D+H exclusively.

Wipe off dirt with a dry, soft cloth.

Do not use any detergents or solvents.

## Disposal

Electrical devices, accessories, batteries and packaging should be recycled in an environmentally responsible manner. Do not throw electrical devices and batteries into the household waste!

Only for EU countries:

In accordance with European Directive 2012/19/EU pertaining to waste electrical and electronic equipment and its implementation in national law, usable electrical devices must be collected separately and submitted for environmentally responsible recycling.



D+H Mechatronic AG  
Georg-Sasse-Str. 28-32  
22949 Ammersbek, Allemagne

Tél. : +4940-605 65 239  
Fax : +4940-605 65 254  
E-mail : [info@dh-partner.com](mailto:info@dh-partner.com)  
[www.dh-partner.com](http://www.dh-partner.com)

Subject to technical modifications.

