

VCD-0203-0250-1-ACB M1-R



Performance features

- + For façade windows, roof windows and ventilation flaps in conservatories
- + With BSY+ motor and synchronised electronics controlled via microprocessor
- + Option of up to 8 drives in one synchronous group
- + Simple connection via plug connector
- + Programmable drive functions and different drive parameters
- + Running speed in CLOSED direction decreases to 5 mm/s (passive closing edge protection)
- + Time-controlled reversing when an obstacle is detected in the CLOSED direction (active closing edge protection)
- + Integrated ACB (Advanced Communication Bus) bus interface with Modbus RTU protocol
- + The drive is integrated directly via open bus communication through the ACB (Advanced Communication Bus), e.g. in a building management system
- + With optional burglary-resistant effect and maximum locking force of 4000 N

Approvals / Certificates

Details of approval on request.



5014068.22003

Technical data

VCD-0203-0250-1-ACB M1-R

Supply	24 V DC / $\pm 20\%$ / 0,35 A
Duty cycle	30 % (ON: 3 min. / OFF: 7 min.)
Force of pressure	200 N
Tensile force	200 N
Nominal locking force **	2000 N / 4000 N ***
Service life	20000 double strokes *
Stroke	250 mm
OPEN running speed	6 mm/s
CLOSED running speed	6 mm/s
Type of protection	IP 30
Emission sound pressure level	LpA \leq 46 dB(A)
Temperature range	0 °C ... +60 °C
Housing	Die-cast zinc
Surface	Powder-coated
Colour	Silver (~ RAL 9006)
Connection	2.5 m PVC-cable
W x H x D	300 x 30 x 47 mm
Weight	1.1 kg
Art. No.	25.155.05

* For vertical use, please consult with D+H Sales!

** Depending on the mounting, *** optionally increased nominal locking force

Dimensions

All specifications in mm

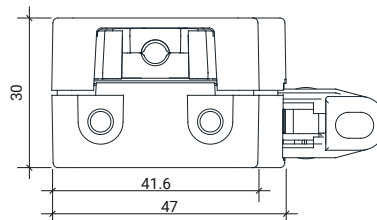
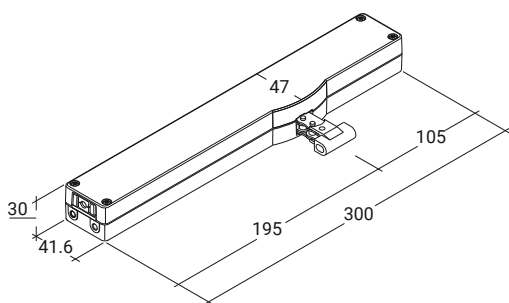

Pressure load diagram

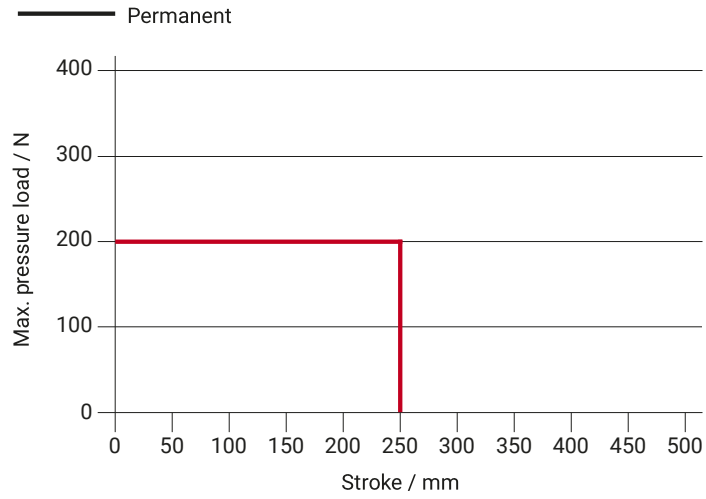

Possible applications

- + Mounted installation
- + Application force
- + Frame mounting
- + Application tension
- + Sash mounting
- + Trapezoidal application

